

DESCRIPTION: M5 MALE - CABLE MOUNT - SOLDER CUP - 4 POSITION

NOTE:

MATERIAL
 HOUSING: TPU, BLACK
 CONTACT: BRASS
 NUT: BRASS

FINISH
 CONTACT: GOLD PLATED
 OVER 50µ" NICKEL
 NUT: SATIN NICKEL

ELECTRICAL
 RATED CURRENT: 1A
 RATED VOLTAGE: 60V
 WATER PROOF: IP67
 ENVIRONMENT
 OPERATION TEMPERATURE: -40°C TO +85°C
 WIRE GAUGE: 26-28 AWG

850-004-103RLUY

1 = GOLD FLASH
 4 = 10µ" GOLD

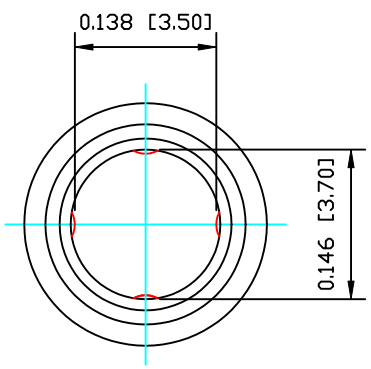
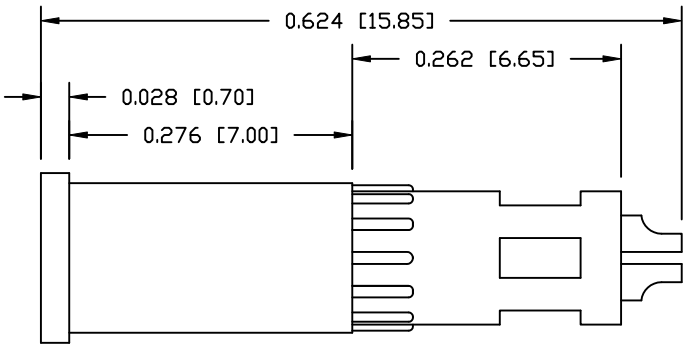
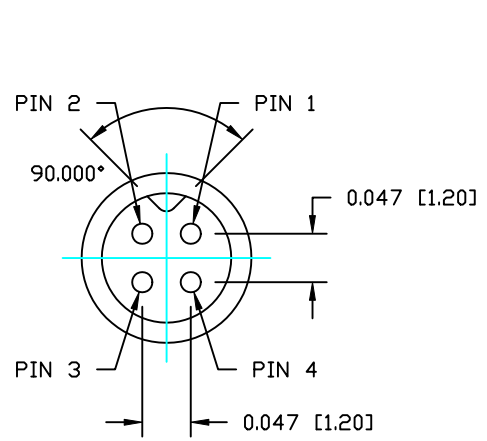

NUT

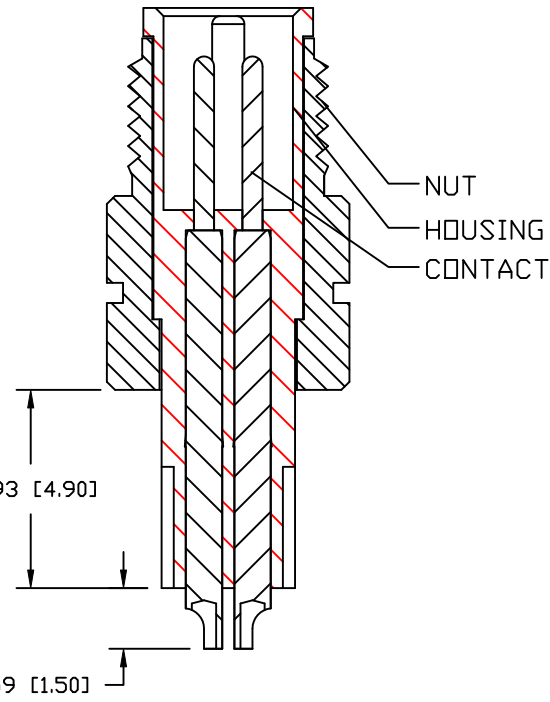
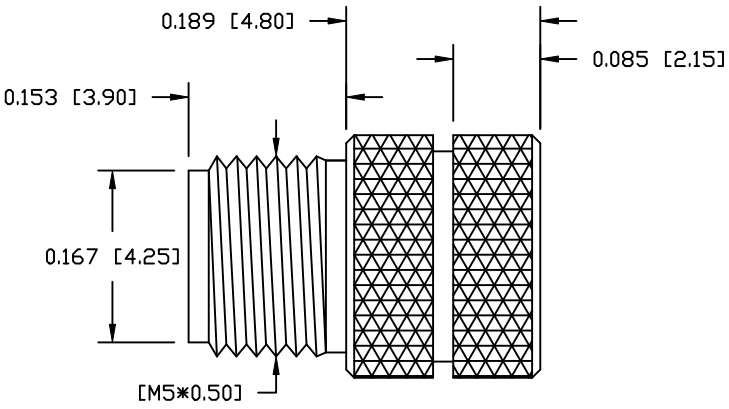

RoHS COMPLIANT

DO NOT SCALE FROM DRAWING



THESE DRAWINGS AND SPECIFICATIONS ARE THE PROPERTY OF NorComp AND SHALL NOT BE REPRODUCED, COPIED OR USED AS THE BASIS FOR THE MANUFACTURE OR SALE OF APPARATUS WITHOUT WRITTEN PERMISSION.

DRAWN: M. SIGMON
DATE: 03-04-16
CHECKED:
DATE:

NorComp

SCALE: NTS
SHEET 1 **OF** 1
REV 0
DWG NO. 850-004-103RLUY