

DESCRIPTION: M8 FEMALE - PANEL MOUNT (REAR) - SOLDER CUP - 4 POS.

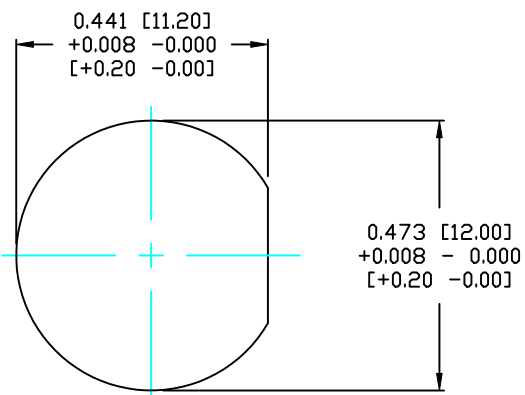

PANEL CUTOUT

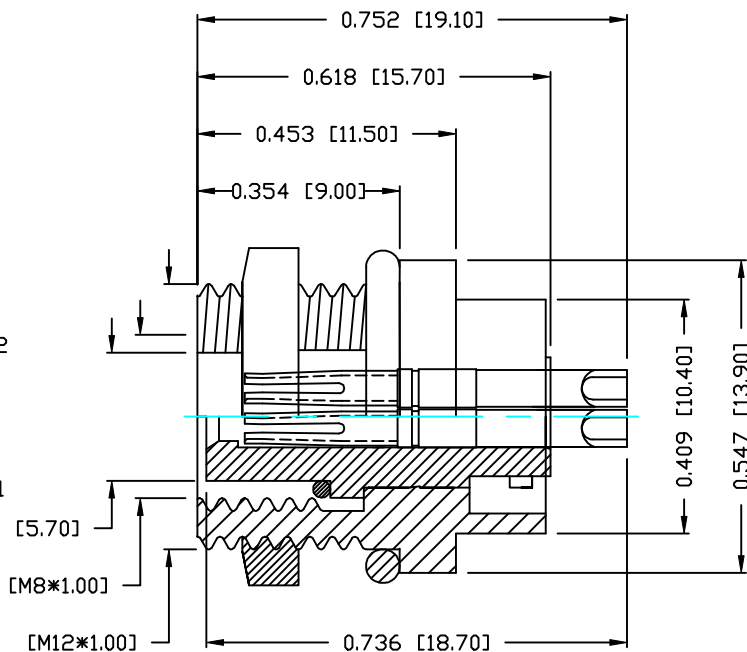
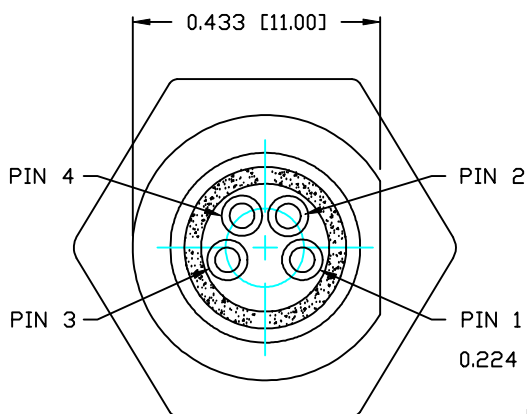

NOTE:

MATERIAL

HOUSING:	PBT UL94V-0, BLACK
CONTACT:	PHOSPHOR BRONZE
SHELL:	BRASS
NUT:	BRASS
O-RING:	NBR, BLACK
FINISH:	
CONTACT:	GOLD PLATED OVER 50µ" NICKEL NICKEL
SHELL:	
ELECTRICAL	
RATED CURRENT:	5A
RATED VOLTAGE:	125V
WATER PROOF:	IP67
ENVIRONMENT	
OPERATION TEMPERATURE:	-40°C TO +85°C
WIRE GAUGE:	24-28 AWG

855-004-203R00Y

1 = GOLD FLASH
4 = 10µ" GOLD

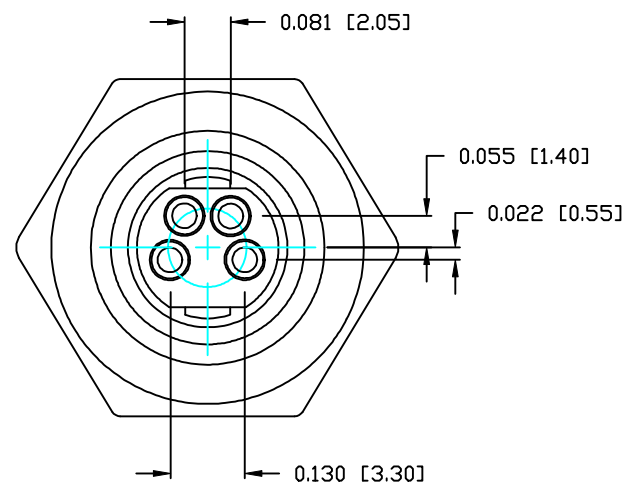

RoHS COMPLIANT

DO NOT SCALE FROM DRAWING



THESE DRAWINGS AND SPECIFICATIONS ARE THE PROPERTY OF NorComp AND SHALL NOT BE REPRODUCED, COPIED OR USED AS THE BASIS FOR THE MANUFACTURE OR SALE OF APPARATUS WITHOUT WRITTEN PERMISSION.

DRAWN: M. SIGMON

DATE: 03-04-16

CHECKED:

DATE:

NorComp

SCALE: N.T.S.

SHEET 1 OF 1

REV 0

DWG NO.

855-004-203R00Y