

DESCRIPTION: M12 MALE - PANEL MOUNT (REAR) - SOLDER CUP - 4 POS.

NOTE:

MATERIAL  
 HOUSING: PBT UL94V-0, BLACK  
 CONTACT: BRASS  
 SHELL: BRASS  
 NUT: BRASS  
 O-RING: EPDM, BLACK  
 FINISH  
 CONTACT: GOLD PLATED  
 OVER 50µ" NICKEL  
 SHELL: NICKEL PLATED OVER ALL  
 NUT: NICKEL PLATED OVER ALL  
 ELECTRICAL:  
 RATED CURRENT: 5A  
 RATED VOLTAGE: 125V  
 WATER PROOF: IP67  
 ENVIRONMENT:  
 OPERATIION TEMPERATURE: -40°C TO +85°C  
 WIRE GAUGE: 24-28 AWG

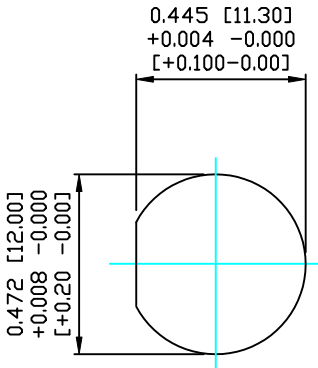

PANEL CUTOUT

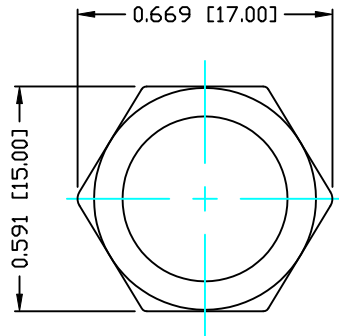

NUT

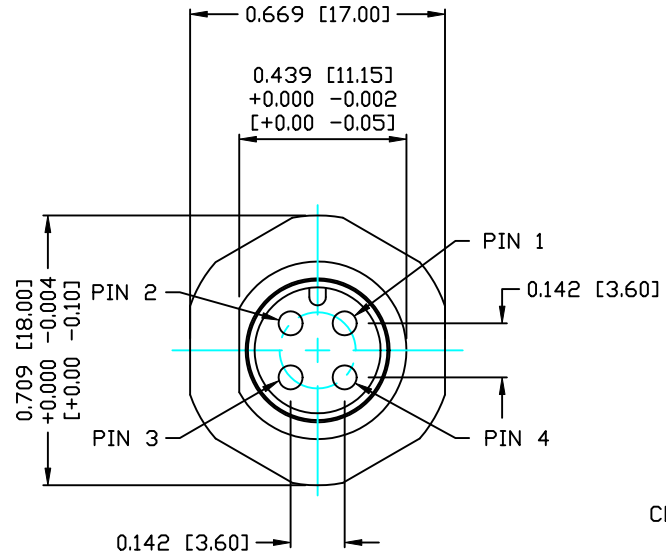
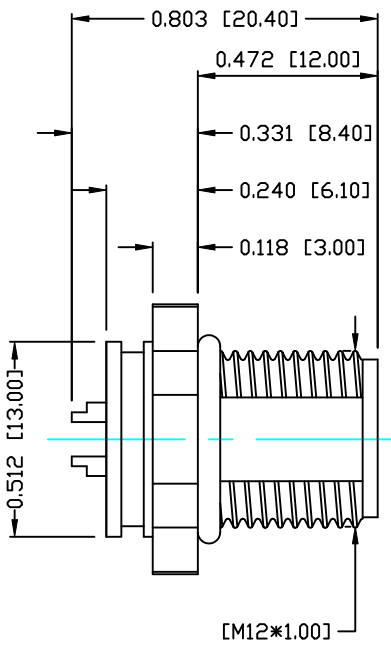
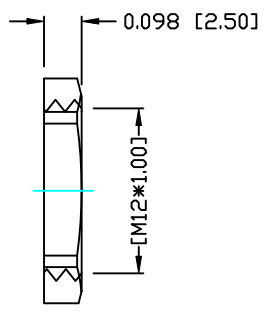

859-004-103R00Y

1 = GOLD FLASH  
 4 = 10µ" GOLD

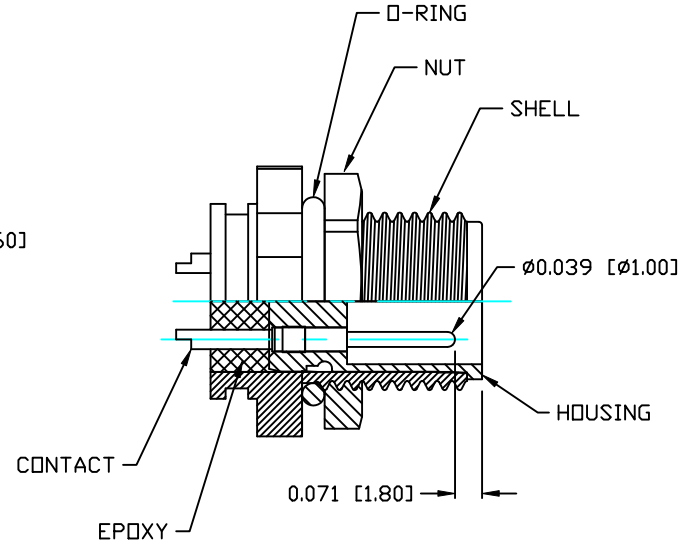

RoHS COMPLIANT

DO NOT SCALE FROM DRAWING



THESE DRAWINGS AND SPECIFICATIONS ARE THE PROPERTY OF NorComp AND SHALL NOT BE REPRODUCED, COPIED OR USED AS THE BASIS FOR THE MANUFACTURE OR SALE OF APPARATUS WITHOUT WRITTEN PERMISSION.

DRAWN: M. SIGMON  
 DATE: 03-07-16  
 CHECKED:  
 DATE:

NorComp

SCALE: N.T.S.  
 SHEET 1 OF 1  
 REV 1  
 DWG NO. 859-004-103R00Y