

**DESCRIPTION: M12 MALE - PANEL MOUNT (REAR) - SOLDER CUP - 8 POS.**

**NOTE:**

<b>MATERIAL</b>	
HOUSING:	PBT UL94V-0, BLACK
CONTACT:	BRASS
SHELL:	BRASS
NUT:	BRASS
O-RING:	EPDM, BLACK
<b>FINISH</b>	
CONTACT:	GOLD PLATED OVER 50µ" NICKEL
SHELL:	NICKEL PLATED OVER ALL
NUT:	NICKEL PLATED OVER ALL
<b>ELECTRICAL:</b>	
RATED CURRENT:	5A
RATED VOLTAGE:	125V
WATER PROOF:	IP67
<b>ENVIRONMENT:</b>	
OPERATION TEMPERATURE:	-40°C TO +85°C
WIRE GAUGE:	24-28 AWG

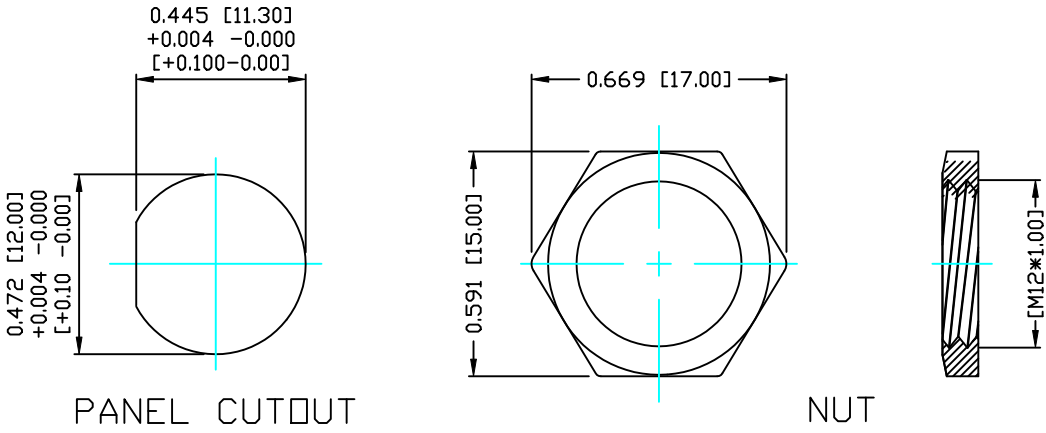

**859-008-103R00Y**

1 = GOLD FLASH  
4 = 10µ" GOLD

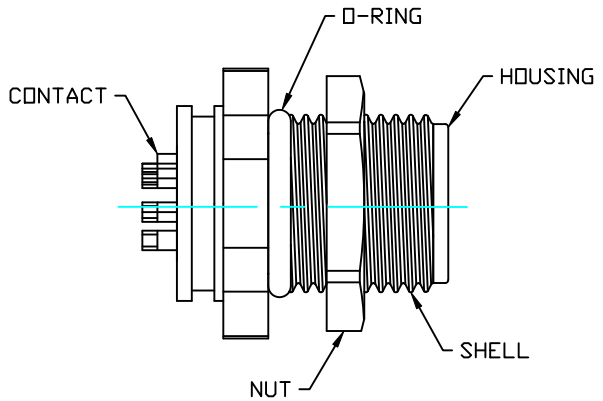
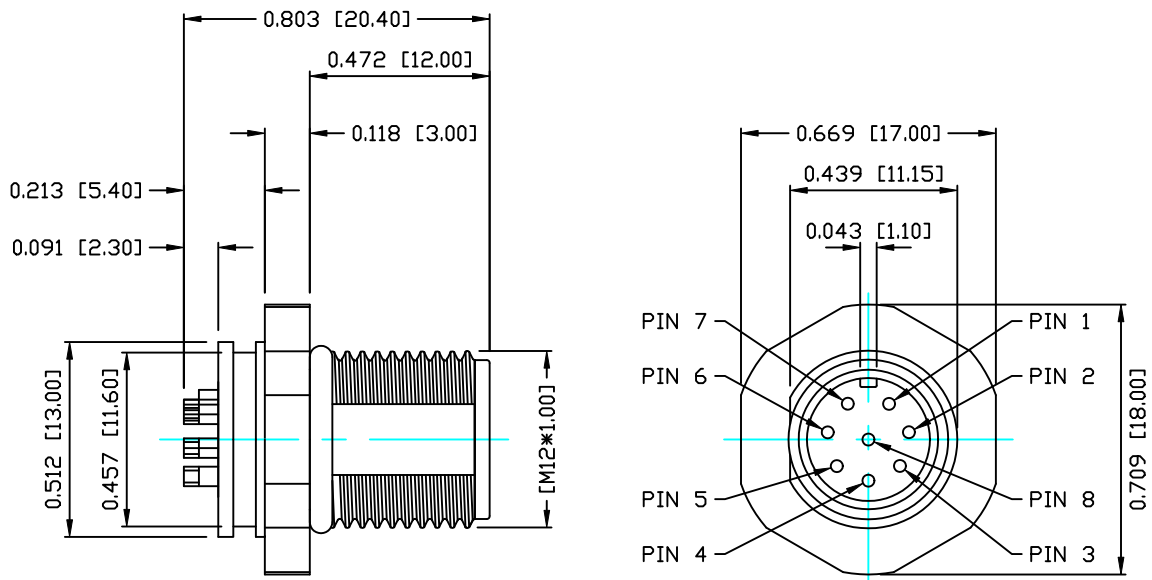

**RoHS COMPLIANT**

**DO NOT SCALE FROM DRAWING**



THESE DRAWINGS AND SPECIFICATIONS ARE THE PROPERTY OF NorComp AND SHALL NOT BE REPRODUCED, COPIED OR USED AS THE BASIS FOR THE MANUFACTURE OR SALE OF APPARATUS WITHOUT WRITTEN PERMISSION.

<b>DRAWN:</b> M. SIGMON	<b>DATE:</b> 03-07-16
<b>CHECKED:</b>	<b>DATE:</b>

**NorComp**

<b>SCALE:</b> N.T.S.	<b>SHEET</b> 1 <b>OF</b> 1	<b>REV</b> 0
<b>DWG NO.</b> 859-008-103R00Y		