

DESCRIPTION: M12 MALE - PANEL MOUNT (REAR) - SOLDER CUP - 3 POS.

NOTE:

MATERIAL	
HOUSING:	PBT UL94V-0, BLACK
CONTACT:	COPPER ALLOY
NUT:	COPPER ALLOY
SHELL:	COPPER ALLOY
O-RING:	EPDM, BLACK
FINISH	
CONTACT:	GOLD PLATED OVER 50µ" NICKEL
NUT:	NICKEL PLATED 60µ" TO 100µ" OVER ALL
SHELL:	NICKEL PLATED 60µ" TO 100µ" OVER ALL
ELECTRICAL	
RATED CURRENT:	5A
RATED VOLTAGE:	125V
WATER PROOF:	IP67
ENVIRONMENT	
OPERATION TEMPERATURE:	-40°C TO +85°C
WIRE GAUGE:	24-28 AWG

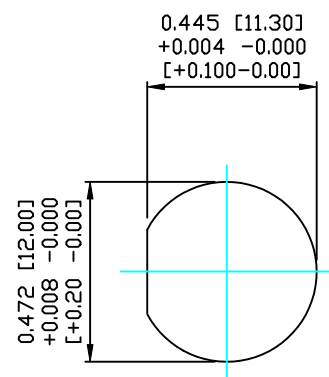

PANEL CUTOUT

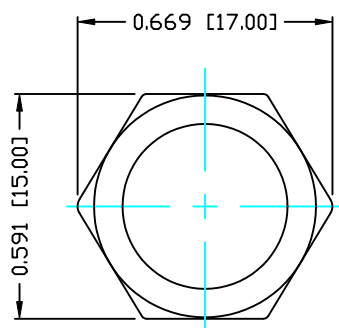

NUT

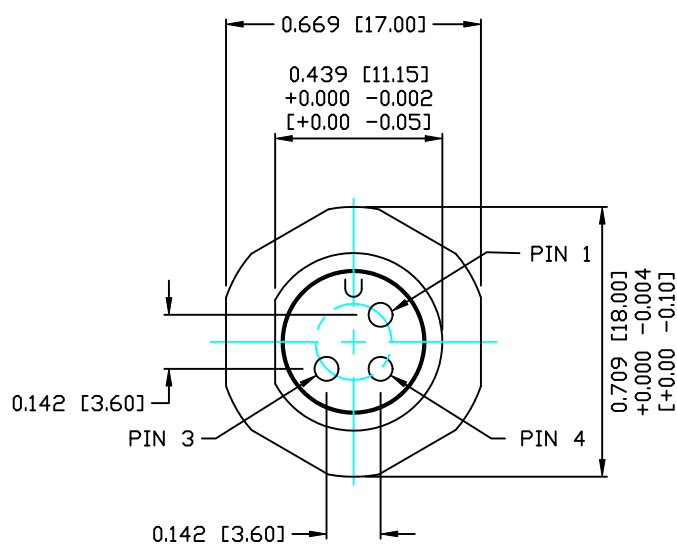
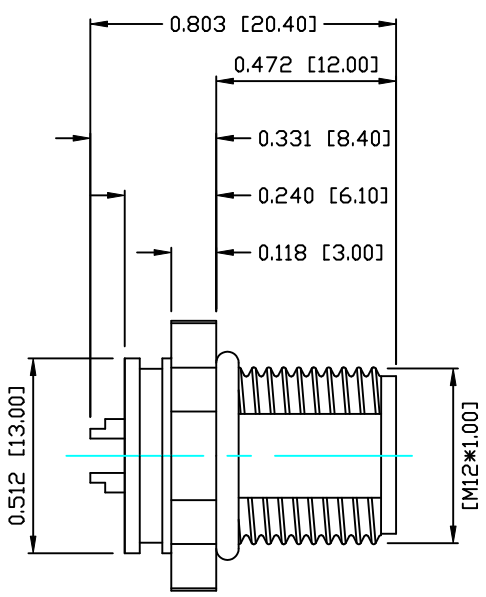
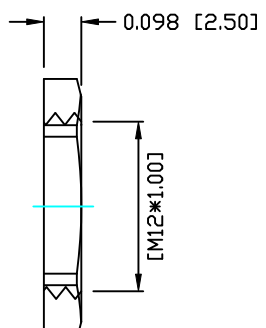

859-R03-103R00Y

1 = GOLD FLASH
4 = 10µ" GOLD

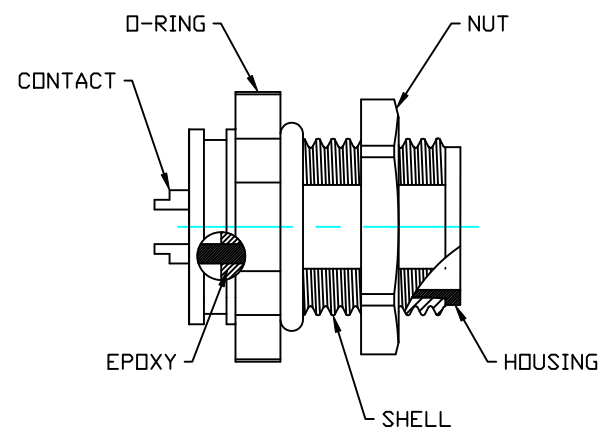

RoHS COMPLIANT

DO NOT SCALE FROM DRAWING



THESE DRAWINGS AND SPECIFICATIONS ARE THE PROPERTY OF NorComp AND SHALL NOT BE REPRODUCED, COPIED OR USED AS THE BASIS FOR THE MANUFACTURE OR SALE OF APPARATUS WITHOUT WRITTEN PERMISSION.

DRAWN: M. SIGMON	DATE: 03-07-16
CHECKED:	DATE:

NorComp

SCALE: N.T.S.	SHEET 1	OF 1	REV 0
DWG NO. 859-R03-103R00Y			