

https://www.phoenixcontact.com/cn/products/0708580



## Panel feed-through terminal block - HDFKV 50-VP - 0708580

Please be informed that the data shown in this PDF Document is generated from our Online Catalog. Please find the complete data in the user's documentation. Our General Terms of Use for Downloads are valid (<http://phoenixcontact.com/download>)



Panel feed-through terminal block, Connection method: Screw connection, Bolt connection, Load current : 150 A, Cross section: 16 mm<sup>2</sup> - 50 mm<sup>2</sup>, AWG 6 - 1/0, Connection direction of the conductor to plug-in direction: 90 °, Width: 18.8 mm, Color: gray

### Why buy this product

- Easy grouping with engagement pin versions
- Both terminal halves can be easily assembled by simply snapping them together
- Touch-proof insulating housing in a new design
- Molded versions ensure maximum tightness of seal
- Automatic compensation of the panel thickness via the snap principle integrated in the insulation housing
- Universal screw connection with screw locking



### Key Commercial Data

Packing unit	10 STK
Minimum order quantity	10 STK
GTIN	 4 017918 004699
GTIN	4017918004699
Custom tariff number	8536901900
Sales Key	AABHDA

### Technical data

#### General

Number of levels	1
Number of connections	2
Nominal cross section	50 mm <sup>2</sup>
Color	gray
Insulating material	PA
Flammability rating according to UL 94	V0
Maximum load current	150 A

<https://www.phoenixcontact.com/cn/products/0708580>

## Panel feed-through terminal block - HDFKV 50-VP - 0708580

### Technical data

#### General

Rated surge voltage	8 kV
Degree of pollution	3
Overvoltage category	III
Insulating material group	I
Connection in acc. with standard	IEC 60947-7-1
Nominal current $I_N$	150 A
Maximum load current	150 A
Nominal voltage $U_N$	690 V
Open side panel	No
Number of positions	1

#### Dimensions

Width	18.8 mm
Length	90 mm
Plate thickness	1 mm ... 6 mm

#### Connection data

Note	Terminal sleeve
Connection side	Level 1 ext. 1
Connection method	Screw connection
Note	Note: Product releases, connection cross sections and notes on connecting aluminum cables can be found in the download area.
Conductor cross section solid min.	16 mm <sup>2</sup>
Conductor cross section solid max.	50 mm <sup>2</sup>
Conductor cross section flexible min.	16 mm <sup>2</sup>
Conductor cross section flexible max.	50 mm <sup>2</sup>
Conductor cross section AWG min.	6
Conductor cross section AWG max.	1/0
Conductor cross section flexible, with ferrule without plastic sleeve min.	10 mm <sup>2</sup>
Conductor cross section flexible, with ferrule without plastic sleeve max.	50 mm <sup>2</sup>
Conductor cross section flexible, with ferrule with plastic sleeve min.	10 mm <sup>2</sup>
Conductor cross section flexible, with ferrule with plastic sleeve max.	50 mm <sup>2</sup>
2 conductors with same cross section, solid min.	6 mm <sup>2</sup>
2 conductors with same cross section, solid max.	16 mm <sup>2</sup>
2 conductors with same cross section, stranded min.	10 mm <sup>2</sup>
2 conductors with same cross section, stranded max.	16 mm <sup>2</sup>
2 conductors with same cross section, stranded, ferrules without plastic sleeve, min.	6 mm <sup>2</sup>
2 conductors with same cross section, stranded, ferrules without plastic sleeve, max.	16 mm <sup>2</sup>
2 conductors with same cross section, stranded, TWIN ferrules with plastic sleeve, min.	6 mm <sup>2</sup>

https://www.phoenixcontact.com/cn/products/0708580



# Panel feed-through terminal block - HDFKV 50-VP - 0708580

## Technical data

### Connection data

2 conductors with same cross section, stranded, TWIN ferrules with plastic sleeve, max.	10 mm <sup>2</sup>
Stripping length	24 mm
Internal cylindrical gage	B10
Screw thread	M6
Tightening torque, min	6 Nm
Tightening torque max	8 Nm
Connection side	Level 1 int. 1
Connection method	Bolt connection
Screw thread	M8
Tightening torque, min	12 Nm
Tightening torque max	15 Nm

### Standards and Regulations

Connection in acc. with standard	CSA
	IEC 60947-7-1
Flammability rating according to UL 94	V0

### Environmental Product Compliance

China RoHS	Environmentally friendly use period: unlimited = EFUP-e
	No hazardous substances above threshold values

## Drawings

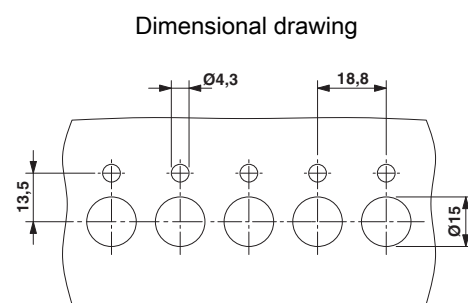
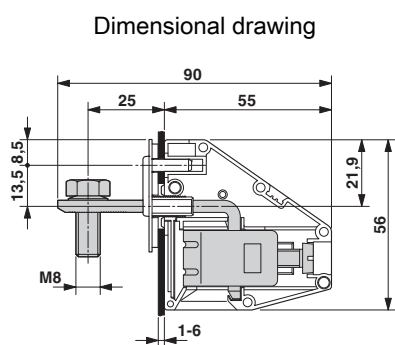

## Approvals

### Approvals

Approvals

CSA / UL Recognized / PRS / IEC EE CB Scheme / EAC

Ex Approvals

<https://www.phoenixcontact.com/cn/products/0708580>





## Panel feed-through terminal block - HDFKV 50-VP - 0708580

### Approvals

#### Approval details

CSA		<a href="http://www.csagroup.org/services/testing-and-certification/certified-product-listing/">http://www.csagroup.org/services/testing-and-certification/certified-product-listing/</a>	13631
	B	C	
mm <sup>2</sup> /AWG/kcmil	6-1/0	6-1/0	
Nominal current IN	125 A	125 A	
Nominal voltage UN	600 V	600 V	

UL Recognized		<a href="http://database.ul.com/cgi-bin/XYV/template/LISEXT/1FRAME/index.htm">http://database.ul.com/cgi-bin/XYV/template/LISEXT/1FRAME/index.htm</a>	E60425-19890329
	B	C	
mm <sup>2</sup> /AWG/kcmil	6-2/0	6-2/0	
Nominal current IN	170 A	170 A	
Nominal voltage UN	600 V	600 V	

PRS		<a href="http://www.prs.pl/">http://www.prs.pl/</a>	TE/1825/880590/09
-----	---	---	-------------------

IECEE CB Scheme		<a href="http://www.iecee.org/">http://www.iecee.org/</a>	NL-29947
mm <sup>2</sup> /AWG/kcmil	50		
Nominal current IN	150 A		
Nominal voltage UN	690 V		

EAC		B.01742
-----	---	---------

Phoenix Contact 2017 © - all rights reserved  
<http://www.phoenixcontact.com>