

HSF

NOTES:
 Current Rating: 1.0AMP
 Contact Resistance: 20mΩ Max
 Withstand Voltage: 500V AC/DC
 Insulation Resistance: 1000MΩ Min
 Operation Temperature: -40°C to +105°C

Contact Material: Phosphor Bronze
 Contact plating: Au over Ni
 Insulator Material: PA9T+30%GF UL94V-0

Recommended P.C.B Layout (Top Side)
 (PCB BOARD TOLERANCE ±0.05)

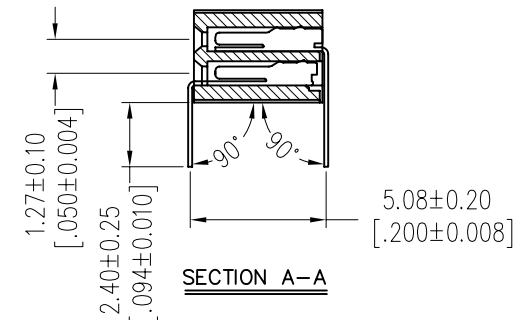
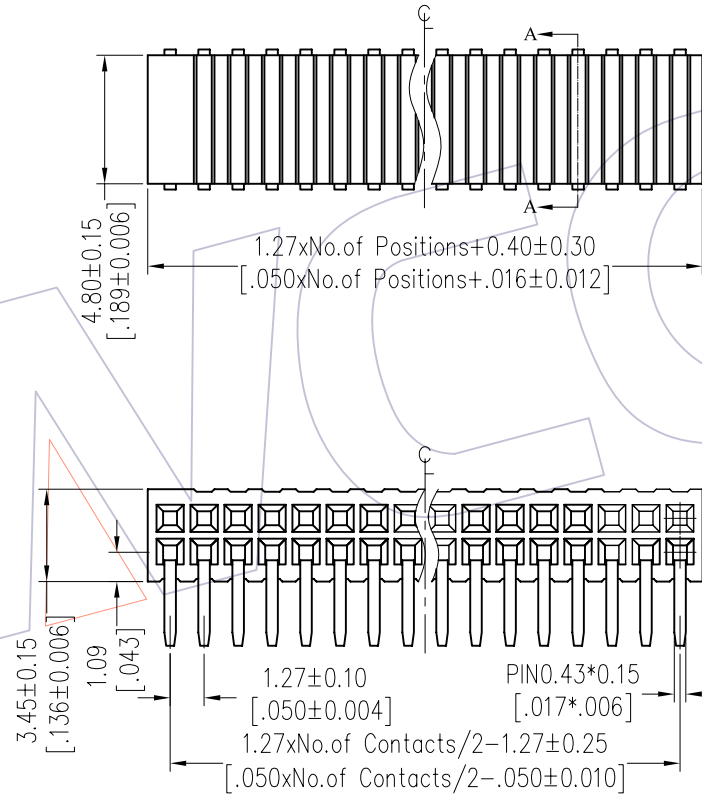
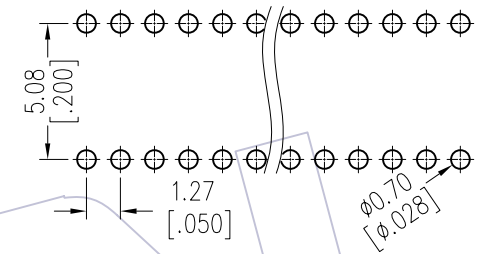

Ordering Information

2335-2 XX R XX CUN T 1

No. of Pins per Row: 02-50 Pin

Contact Plating:
 G0=Gold Flash
 G3=10μ"Gold
 G4=15μ"Gold
 G5=30μ"Gold

Packing:
 T=Tube

Item	Pitch	Mating
Standard	1.27	1310/1315/1320
Alternate		

REV	DATE	MODIFICATION DESCRIPTION	CHANGE	OPERATION	DRAW	DATE	SCALE	FIT	PART NO.
				x.x ±0.40	JYHuang	2012/07/07	UNIT	mm	2335-2XXRXXCUNT1
				x.xx ±0.25	CHECK	DATE	SIZE	A4	
				x.xxx ±0.15	APPROVE	DATE	SHEET	1/1	TITLE: FH1.27 DUAL SIDE INSERT 90° H=3.45
				Angle ± 3'			PROJ.	☉	Customer NO.
				DIM TOL					