

HSF

Recommended P.C.B Layout(Top Side)
(PCB BOARD TOLERANCE±0.05)

NOTES:

Current Rating: 3.0AMP
 Contact Resistance: 20mΩ Max
 Withstand Voltage: 1000V AC/DC
 Insulation Resistance: 1000MΩ Min
 Operation Temperature: -40°C to +105°C

Contact Material:Brass
 Contact plating:Au Or Sn over Ni
 Insulator Material:PBT+30%G.F UL94V-0 

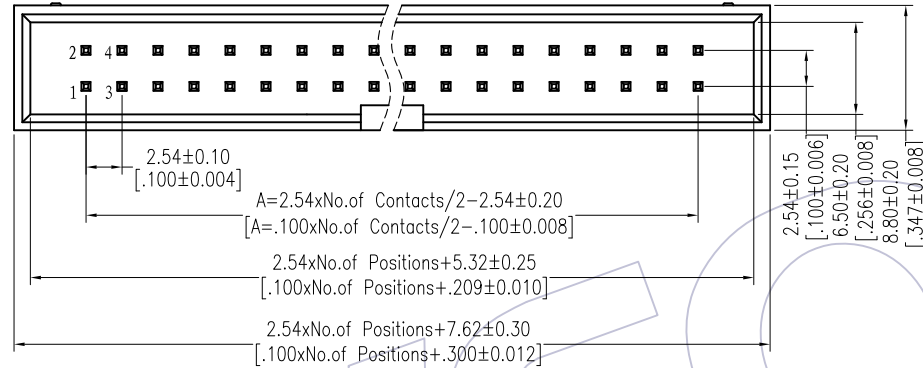
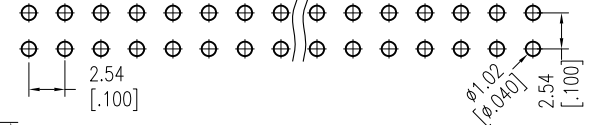

Ordering Information

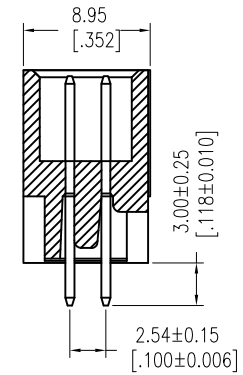
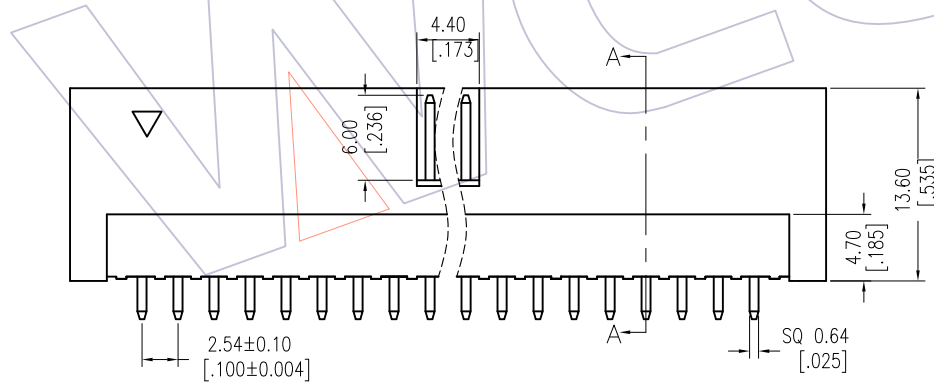

3112-XX S XX B K00 X 1

No.of Pins	Contact Plating	Color Insulator	Packing:
10P 30P	G0=Gold Flash	B=Black	A=Tray
14P 34P	G3=10u"Gold	U=blue	T=Tube
16P 40P	G4=15u"Gold	G=Gray(427C)	
20P 50P	G5=30u"Gold	E=Gray(413C)	
24P 60P	S0=Gold Flash/Tin		
26P 64P	S3=10u"Gold/Tin		
	S4=15u"Gold/Tin		
	S5=30u"Gold/Tin		
	SN=Tin		



A(TOLERANCE)

ITEM	≤20P	>20P
A	±0.20	±0.30

				OPERATION	DRAW	DATE	SCALE	FIT	PART NO.
				x.X ±0.40	Allen	2014/05/05	UNIT	mm	3112-XXSXXBK00XX
A1	2014/05/05	MODIFY		x.XX ±0.25	CHECK	DATE	SIZE	A4	TITLE:
AO	2012/09/25	NEW	-----	x.XXX ±0.15	APPROVE	DATE	SHEET	1/1	2.54 BOX HEADER 180° H=13.6
REV	DATE	MODIFICATION DESCRIPTION	CHANGE	Angle ± 3'			PROJ.		Customer NO.
				DIM TOL					