

# HSF

## NOTES:

Current Rating: 3.0AMP  
 Contact Resistance: 20mΩ Max  
 Withstand Voltage: 1000V AC/DC  
 Insulation Resistance: 1000MΩ Min  
 Operation Temperature: -40°C to +105°C

Contact Material: Phosphor Bronze  
 Contact plating: Au Or Sn over Ni  
 Insulator Material: PA9T+30%G.F UL94V-0

Recommended P.C.B Layout (Top Side)  
 (PCB BOARD TOLERANCE ±0.05)

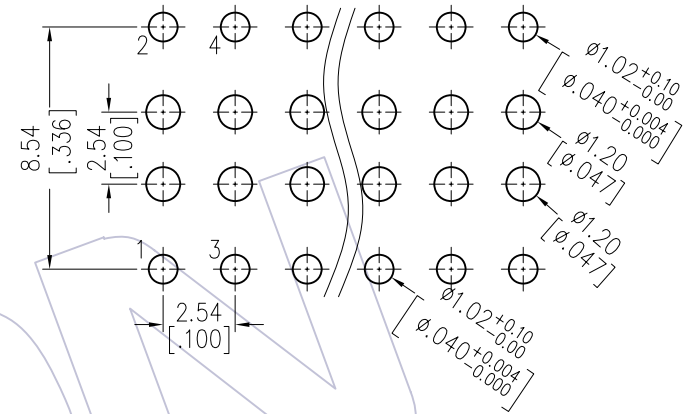
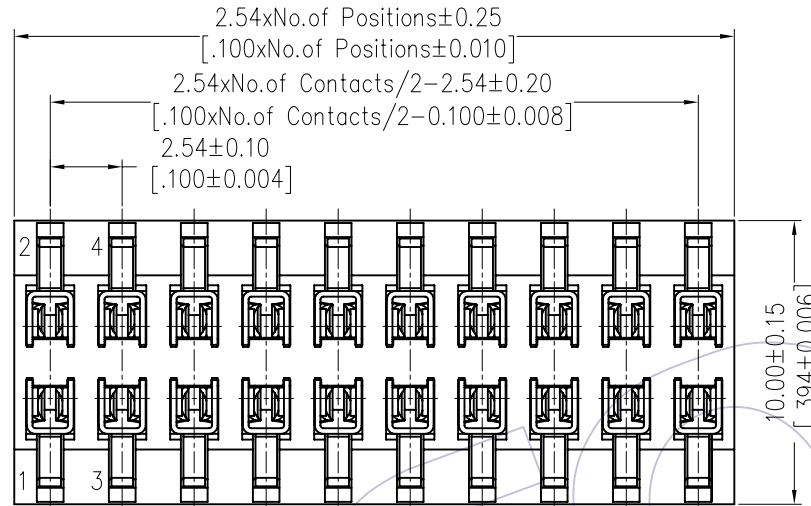

## Ordering Information

2150T - 2 XX W XX CUN X 1

No. of Pins per ROW: 02-40PIN

Contact Plating:  
 G0=Gold Flash  
 G3=10μ"Gold  
 G4=15μ"Gold  
 G5=30μ"Gold  
 S0=Gold Flash/Tin  
 S3=10μ"Gold/Tin  
 S4=15μ"Gold/Tin  
 S5=30μ"Gold/Tin  
 SN=Tin  
 SM=Matte Tin

Packing:  
 T=Tube

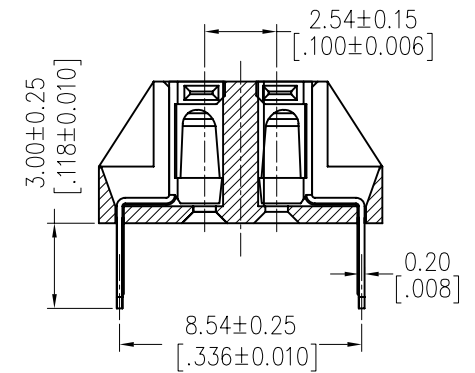
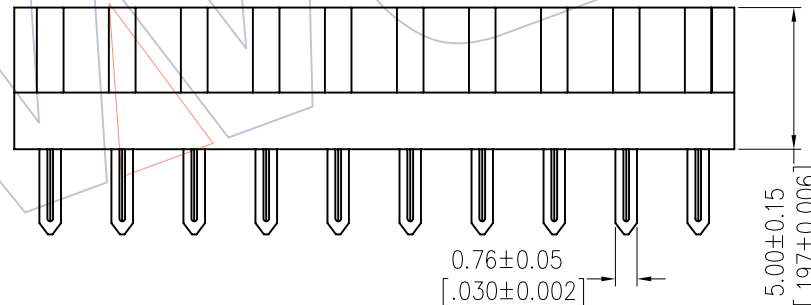

Item	Pitch	Mating
Standard	2.54	1115/1120/1125
Alternate		

				OPERATION	DRAW	DATE	SCALE	FIT	PART NO.	
				X.X ±0.40	JYHuang	2012/08/06	UNIT	mm	2150T-2XXWXXCUNX1	
				X.XX ±0.25	CHECK	DATE	SIZE	A4	TITLE: FH2.54 Double Row Centipede Feet H=5.0 Top Enter	
				X.XXX ±0.15	APPROVE	DATE	SHEET	1/1	Customer NO.	
AO	2012/08/06	NEW	-----	Angle ± 3'			PROJ.			
REV	DATE	MODIFICATION DESCRIPTION	CHANGE	DIM	TOL					