

HSF

NOTES:

Rated Current:1.0AMP
 Contact Resistance:30mΩ max
 Withstand Voltage:500V AC/DC
 Insulation Resistance:1000MΩ min
 Operation Temperature:-55°C to +85°C

Contact Material:Phosphor Bronze
 Contact Plating:Sn Over Ni
 Insulator Material:Thermoplastic UL94V-0

Recommended P.C.B Layout(Top Side)
 (PCB BOARD TOLERANCE±0.05)

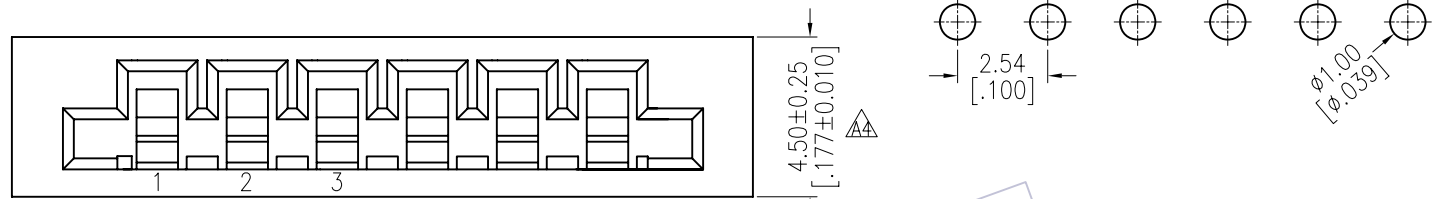

Ordering Information

5110-XX S D D N XT01

No.of Pins
03-27P

Color
 A=Brown
 B=Black
 W=White
 E=Beige

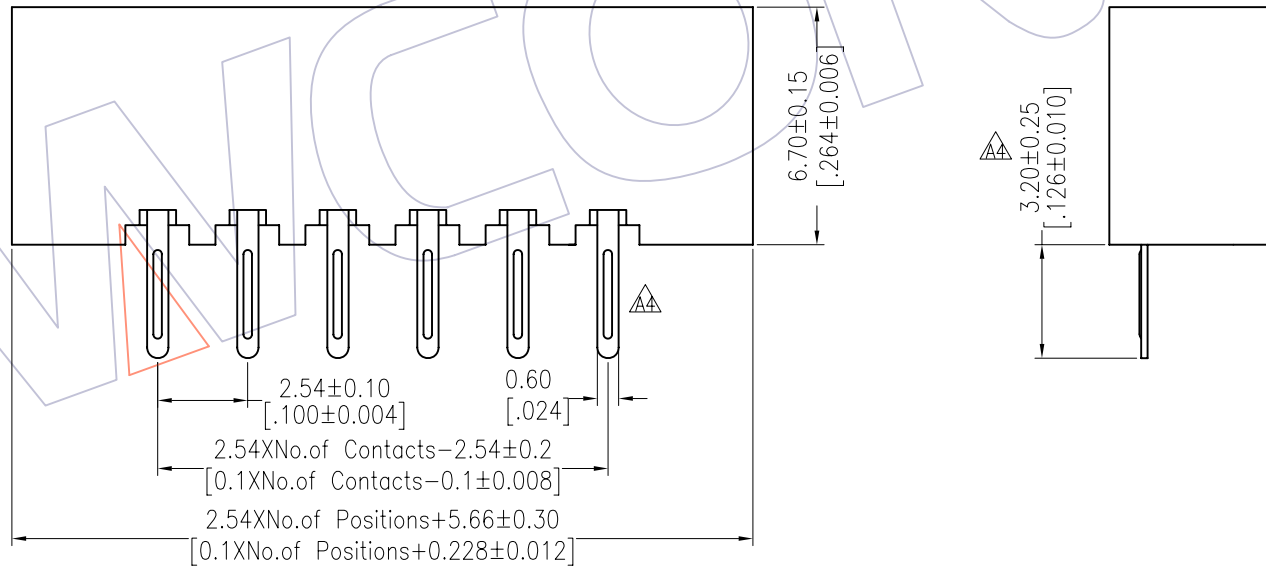

A4	11/11/17	3.00 → 3.20 4.55 → 4.50 0.65 → 0.60	——	——	OPERATION		DRAW	MYQ	11.11.17	SCALE	FIT		
A3	11/07/1	Modify Drawing	——	——	X.X	±0.40	DESIGN			UNIT	mm		
A2	10/12/02	5110-XXSDDNX01 → 5110-XXSDDNWT01	——	——	X.XX	±0.25				SIZE	A4	PART NO.	
A1	09/08/11	3.20 → 3.00	——	——	X.XXX	±0.15	CHECK			SHEET	1/1	TITLE:	
REV	DATE	MODIFICATION DESCRIPTION	CHANGE	APPROVE	Angle	± 3'	APPROVE			PROJ.	☉	Customer NO.	
					DIM	TOL							