

HSF

NOTES:
 Current Rating: 2.0AMP
 Contact Resistance: 20mΩ Max
 Withstand Voltage: 500V AC/DC
 Insulation Resistance: 1000MΩ Min
 Operation Temperature: -40°C to +105°C

Contact Material: Brass 
 Contact plating: Au Or Sn over Ni
 Insulator Material: PA9T+30%G.F UL94V-0

Recommended P.C.B Layout(Top Side)
 (PCB BOARD TOLERANCE±0.05)

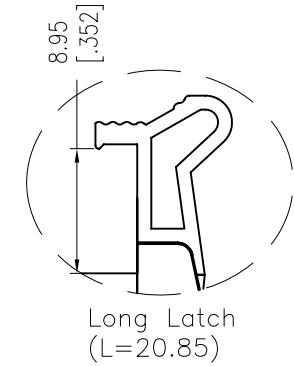
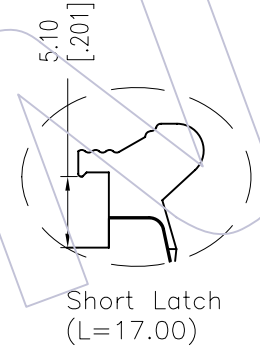
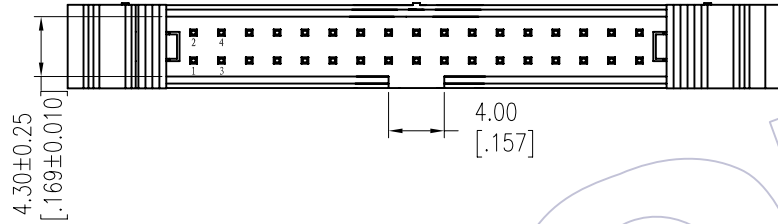
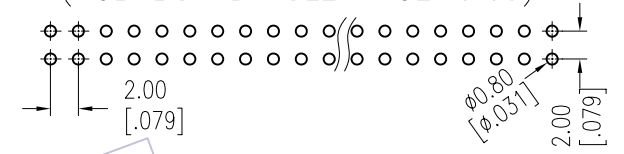

Ordering Information

3220 - XX S XX B X X 1

No. of Pins	Contact Plating	Insulator Color	Latch type	Packing
08 30	G0=Gold Flash	B=Black	L=Long Latch	T=Tube
10 34	G3=10u"Gold	U=Blue	S=Short Latch	
14 40	G4=15u"Gold	G=Grey(427C)		
16 44	G5=30u"Gold	E=Grey(413C)		
20 50	S0=Gold Flash/Tin			
24 60	S3=10u"Gold/Tin			
26 64	S4=15u"Gold/Tin			
68	S5=30u"Gold/Tin			
	SN=Tin			

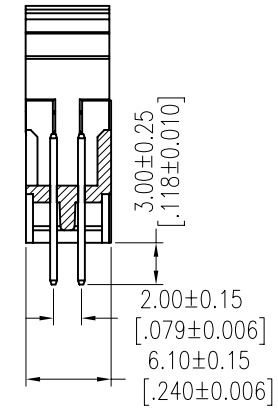
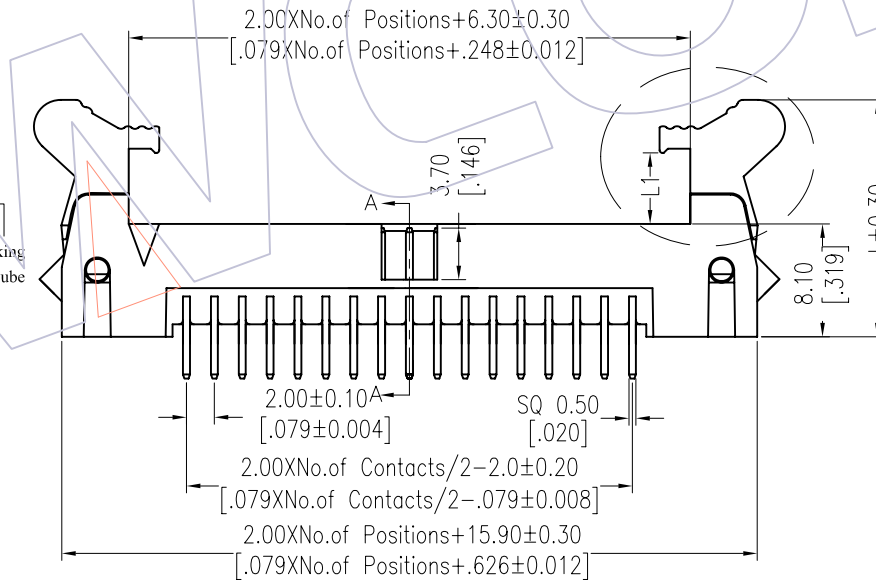

Item	Pitch	Mating
Standard	2.00	5222
Alternate		

REV	DATE	MODIFICATION DESCRIPTION	CHANGE	OPERATION	DRAW	DATE	SCALE	FIT	PART NO.
				x.x ±0.40	JYHuang	2012/12/24	UNIT	mm	3220-XXSXXBXX1
A1	2012/12/24	MODIFY THE NOTES: Phosphor Bronze → Brass	-----	x.xx ±0.25	CHECK	DATE	SIZE	A4	TITLE: 2.00 EJECTOR HEADER 180°
AO	2012/10/08	NEW	-----	x.xxx ±0.15			SHEET	1/1	
				Angle ± 3'	APPROVE	DATE	PROJ.		Customer NO.
				DIM TOL					