

# HSF

**NOTES:**

Rated Voltage:100V AC/DC  
 Rated Current:1.0AMP  
 Contact Resistance:20mΩ max  
 Withstand Voltage:500V AC/DC  
 Insulation Resistance:100MΩ min  
 Operation Temperature:-25°C to +85°C

Contact Material:Brass  
 Contact plating:Au Or Sn Over Ni  
 Insulator Material:PA6T+30%G.F UL94V-0



Recommended P.C.B Layout(Top Side)  
 (PCB BOARD TOLERANCE±0.05)

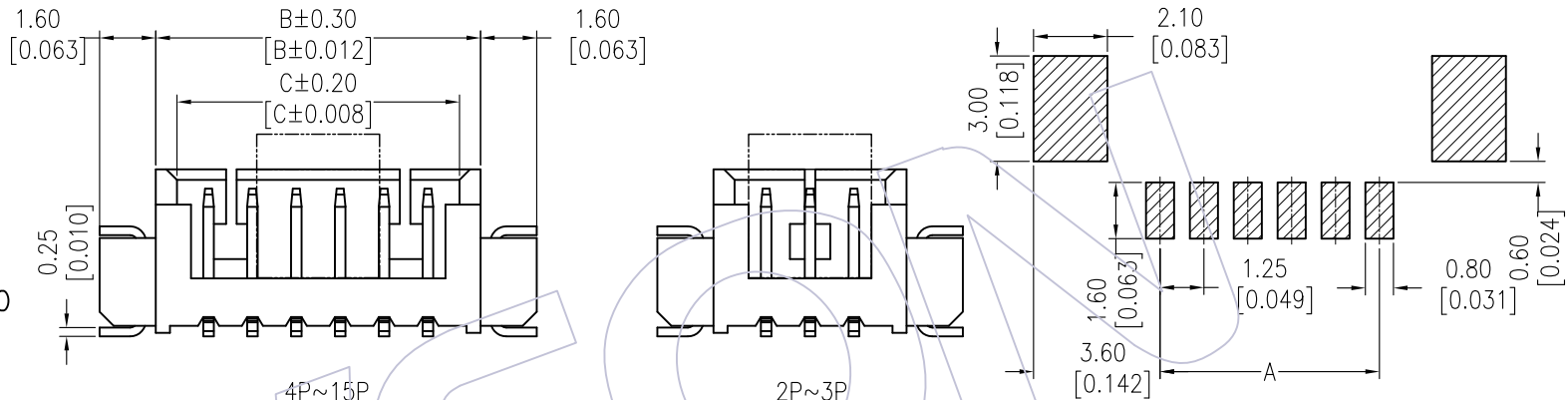

## Ordering Information

WF1251 - WM **XX** **X** **X** **X**

No.of pins  
02-15P

Contact Plating  
 S0=Gold Flash/Tin  
 S3=10u"Gold/Tin  
 S4=15u"Gold/Tin  
 S5=30u"Gold/Tin  
 G0=Gold Flash  
 G3=10u"Gold  
 G4=15u"Gold  
 G5=30u"Gold  
 Blank=Tin

Color  
 W=Natural

Packing  
 A=Tray  
 T=Tube  
 R=Reel+Cap

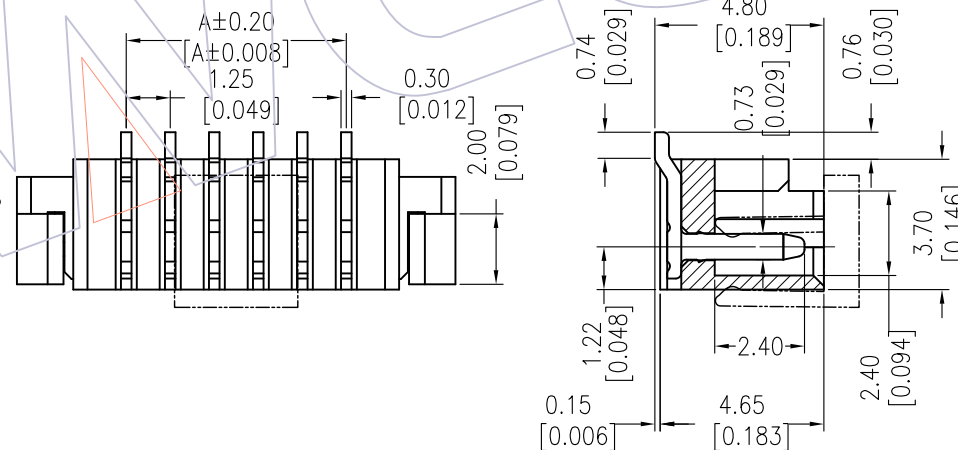

## Specification & Ordering Information:

Circuit	Part No.	Dimension			Q'ty /Tube
		A	B	C	
02	WF1251-WM02XXX	1.25	4.25	3.05	75
03	WF1251-WM03XXX	2.50	5.50	4.30	64
04	WF1251-WM04XXX	3.75	6.75	5.55	56
05	WF1251-WM05XXX	5.00	8.00	6.80	50
06	WF1251-WM06XXX	6.25	9.25	8.05	45
07	WF1251-WM07XXX	7.50	10.50	9.30	41
08	WF1251-WM08XXX	8.75	11.75	10.55	37
09	WF1251-WM09XXX	10.00	13.00	11.80	34
10	WF1251-WM10XXX	11.25	14.25	13.05	31
11	WF1251-WM11XXX	12.50	15.50	14.30	30
12	WF1251-WM12XXX	13.75	16.75	15.55	28
13	WF1251-WM13XXX	15.00	18.00	16.80	26
14	WF1251-WM14XXX	16.25	19.25	18.05	25
15	WF1251-WM15XXX	17.50	20.50	19.30	24

REV	DATE	MODIFICATION DESCRIPTION	CHANGE	OPERATION	DRAW	DATE	SCALE	FIT	PART NO.
A2	2014/07/11	Modify The Color:W=Natural	---	X.X ±0.40	JYHuang	2014/07/11	UNIT	mm inch	SEE TAB
A1	2014/03/13	Modify The Material:PA9T--PA6T	---	X.XX ±0.25	CHECK	DATE	SIZE	A4	TITLE:
AO	2012/08/24	NEW	---	X.XXX ±0.15	APPROVE	DATE	SHEET	1/1	"M" TYPE 1.25 Wafer 180° SMT
				Angle DIM TOL			PROJ.	⌀	Customer NO.