

HSF

NOTES:

Current Rating: 3.0AMP
 Contact Resistance: 25mΩ Max
 Withstand Voltage: 500V AC/Minute
 Insulation Resistance: 1000MΩ Min
 Operation Temperature: -55°C to +105°C

Contact Material:Brass
 Contact plating: Au Or Sn over Ni
 Insulator Material: PA66+30%G.F UL94V-0
 Shell: Cold Roller Steel, Ni Plated
 Revit/Harpoon: Brass, Sn Over Ni Plated

Ordering Information

6215B-15 F M N S1 B 01

No. of Pins	Product Type	Contact Plating	Insulator Color
15P	M=With Revit Without Screw	S0=Gold Flash/Tin S3=10u"Gold/Tin S4=15u"Gold/Tin S5=30u"Gold/Tin SN=Tin	B:Black U:Blue

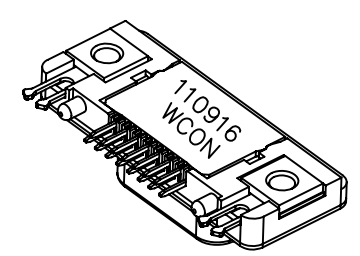
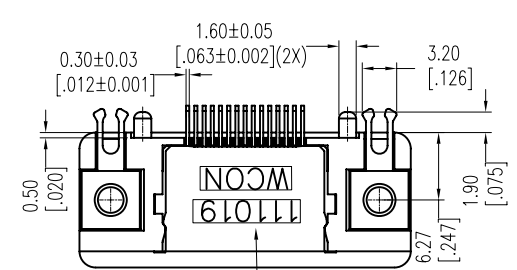
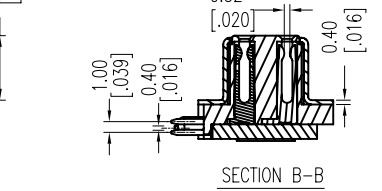
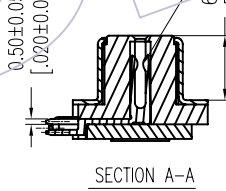
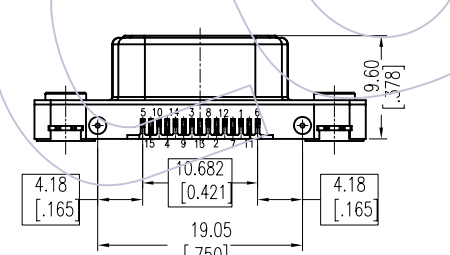
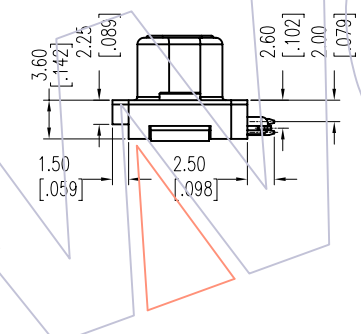
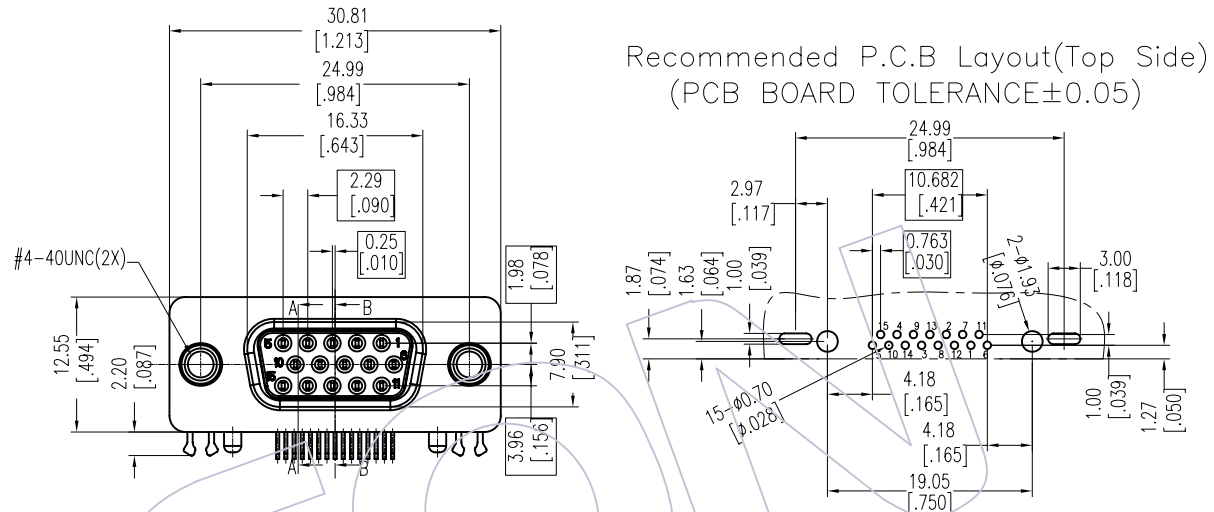

Print Date Code AND LOGO

				OPERATION	DRAW	DATE	SCALE	FIT	PART NO.
				x.x ±0.40	JYHuang	2012/12/18	UNIT	mm	6215B-15FMNS1B01
				x.xx ±0.25	CHECK	DATE	SIZE	A4	TITLE:
				x.xxx ±0.15	APPROVE	DATE	SHEET	1/1	Slim HD/R 15P FEMALE, 90° DIP, Short 9PIN
AO	2012/12/18		NEW	Angle ± 3'			PROJ.	Customer NO.	
REV	DATE		MODIFICATION DESCRIPTION	DIM TOL					