

Gesamtlänge im montierten Zustand ca. 72,2/
complete length when assembled app. 72,2

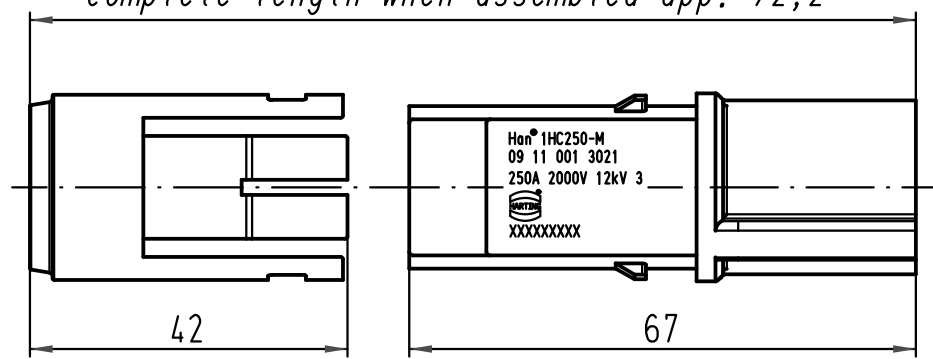

Halteplatte und Montageanleitung lose beigelegt/
fixing plate and assembly instructions enclosed separately

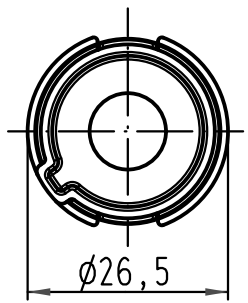
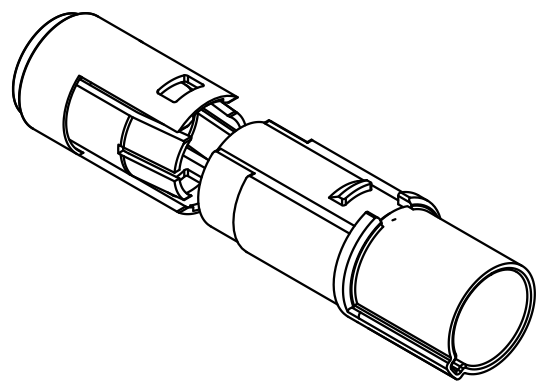

All Dimensions in mm Original Size DIN A 4			Techn. Character.			Nicht tolerierte Maßel Free size tolerances		
				Dat.	Name	Maßstab/ Scale 1:1	Han 1HC250-M	
			Detail.	12.07.10	Ho			
			Insp.		Ole			
			Stand.					
B	13.09.10	ML	HARTING Electric GmbH & Co. KG				TB 09 11 001 3021	
A			D-32339 Espelkamp					
Mod.	Dat.	Name					Sub.	Blatt/ page /