

Gesamtlänge im montierten Zustand ca. 72/
complete length when assembled app. 72

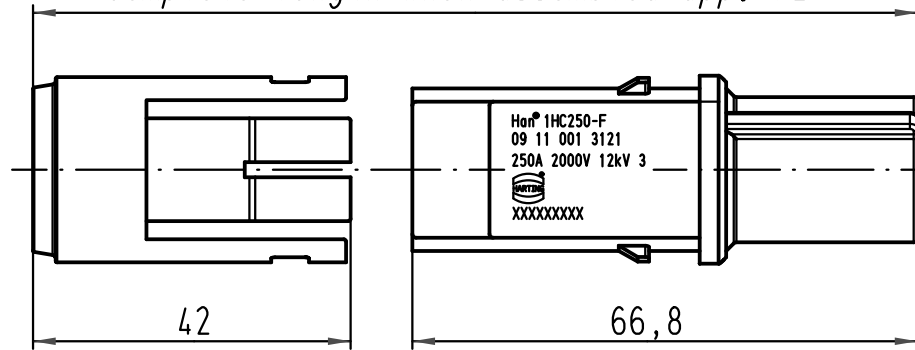

Halteplatte und Montageanleitung lose beigelegt/
fixing plate and assembly instructions enclosed separately

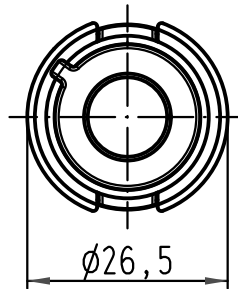
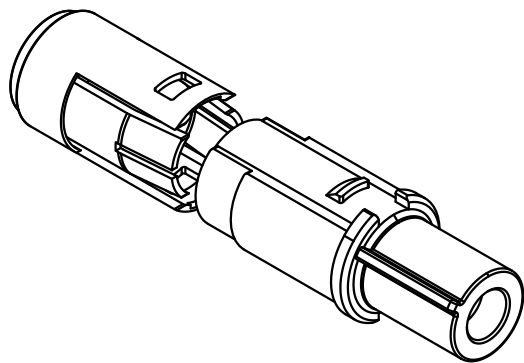

| | | | | | | |
|---|----------|-------------------|--------------------------------|------|--|--------------|
| All Dimensions in mm Original Size DIN A 4 | | Techn. Character. | | | Nicht tolerierte Maße/Free size tolerances | |
| | | | Dat. | Name | Maßstab/Scale 1:1 | Han 1HC250-F |
| | | Detail. | 12.07.10 | Ho | | |
| | | Insp. | | Ole | | |
| | | Stand. | | | | |
| B | 13.09.10 | ML | HARTING Electric GmbH & Co. KG | | TB 09 11 001 3121 | Blatt/ page |
| A | | | D-32339 Espelkamp | | | |
| Mod. | Dat. | Name | | | | |