

# 0.4/0.5mm Pitch 1.5mm Height High Speed Transmission (5+ Gbps) FPC Connectors

## FH55/FH55M Series

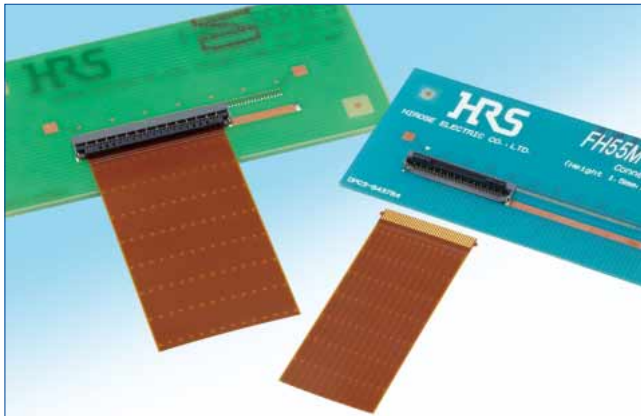

Dimensions : 40 pos

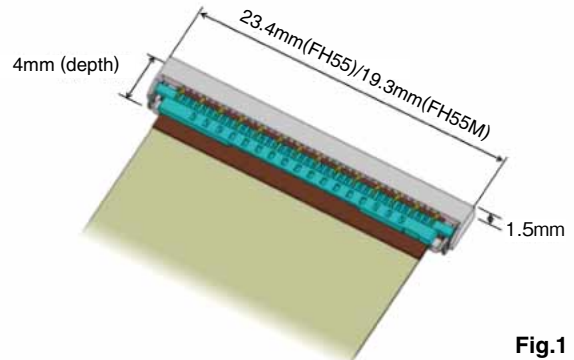

Fig.1

### Features

#### 1. High-Speed Transmission(5+ Gbps) FPC Connectors

Capable of transmitting high-speed differential signals by arranging signal contacts (S) and ground contacts (G) in the sequence of GSSG. (5+ Gbps) (The GSSG layout utilizes differential signals, but the contacts can also be designated for other uses other than differential signals.)

#### 2. Impedance Matched-Contact Design

The signal contacts were designed with impedance control in mind and to realize superior high-speed transmission feature.(Fig.2)

#### 3. Fully Enclosed Molded Structure (Over molding Structure)

Board space under the connector can be utilized in patterning since the bottom of the connector is covered with resin and enhances PCB flexibility.

#### 4. Flip-Lock System Provides Reliability and FPC Security

The Flip-lock (one-touch rotational lock) ZIF structure allows for a reliable and simple to secure FPC connection operation. Utilizing a clear clicking feeling at the time of locking prevents an incomplete lock.

#### 5. Easy FPC insertion

The FPC guiding system utilizes guide tabs that enable a temporary hold while FPC is inserted and accurately determines mating location all while ensuring a consistent connection.

#### 6. Compatible with 0.3mm Thick FPC

This connector utilizes 0.3mm thick FPC, which is the standard thickness of a 0.5mm pitch connector (Appropriate stiffness with reinforcing board prevents FPC deformation, preventing troubles at times of insertion and mating).

#### 7. Automatic Mounting Option Available

Emboss packaging makes automatic mounting possible (5,000 pcs/reel).

#### 8. Halogen-free

Chlorine and bromine are not used in amounts that exceed the standard values in these connectors.

\* Defined according to IEC 61249-2-21

Br : 900ppm or below ; Cl : 900ppm or below ; Br + Cl : 1,500ppm or below

FH55 differential impedance  
50 ps rise time (20-80%)

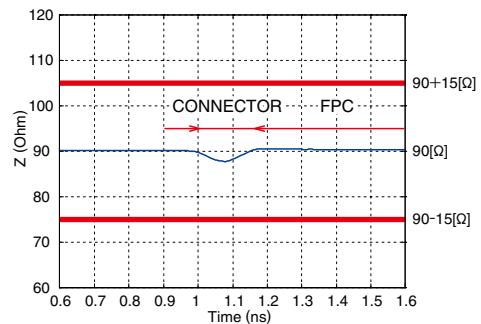

Fig.2

FH55 eye diagram (5 Gbps)

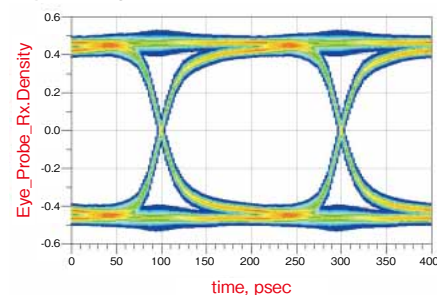

Fig.3

FPC Insertion

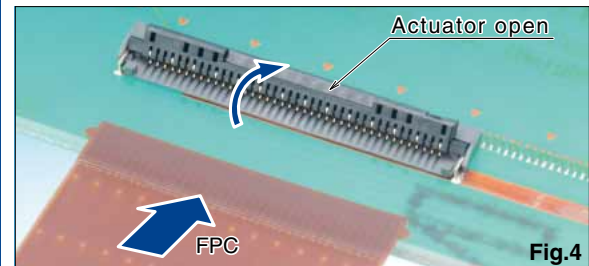

Fig.4

Locked



Fig.5

May.1.2016 Copyright 2016 HIROSE ELECTRIC CO., LTD. All Rights Reserved.

## Product Specifications

Ratings	Current rating	0.5A (0.5mm pitch products)(Note 1) 0.4A (0.4mm pitch products)(Note 1)	Operating temperature range	-55 to +85°C (Note 2)	Storage temperature range	-10 to +50°C (Note 3)
	Voltage rating	AC 50V rms (0.5mm pitch products) AC 40V rms (0.4mm pitch products)	Operating humidity range	RH 90% or less (no condensation)	Storage humidity range	RH 90% or less (no condensation)

Suitable FPC/FFC contact specifications	t = 0.3 ± 0.03 gold-plated
---	----------------------------

Items	Specifications	Conditions
1. Insulation Resistance	500MΩ min	Measured at DC 100V
2. Withstanding Voltage	No flashover or breakdown	AC 150Vrms applied for 1 minute
3. Contact Resistance	100mΩ max * Including FPC conductor resistance	Measured at 1mA
4. Repeat Performance	100mΩ max No breakage, cracking, or loosening to parts	20 times
5. Vibration Resistance	No electric outage of 1μ or greater Contact resistance : 100mΩ max No breakage, cracking, or loosening to parts	10 cycles in each of three directions at frequency 10-55 Hz, half amplitude 0.75mm
6. Shock Resistance	No electric outage of 1μ or greater Contact resistance : 100mΩ max No breakage, cracking, or loosening to parts	Acceleration of 981m/s <sup>2</sup> ; duration 6ms, sine half-wave, 3 cycles in each of the 3 axes each in both directions
7. Humidity Resistance in Steady State	Contact Resistance : 100mΩ max Insulation Resistance : 50MΩ min No breakage, cracking, or loosening to parts	96 hours at temperature 40°C and humidity 90-95%
8. Temperature Cycle	Contact Resistance : 100mΩ max Insulation Resistance : 50MΩ min No breakage, cracking, or loosening to parts	Temperature : -55°C → +15°C to +35°C → +85°C → +15° to +35°C Time : 30 → 2 to 3 → 30 → 2 to 3 minutes 5 cycles with the above conditions
9. Solder Heat Resistance	No marked instability in contacts, or appearance of deformation.	1) Reflow : Peak temperature MAX 250°C, 230°C or greater for 60 seconds 2) Soldering iron : 350±10°C for 5 seconds

Note 1 : Use at 70% of the current rating when all pins are energized with current rating.

Note 2 : Temperature rise at the time of electrification is included.

Note 3 : The term "storage" refers to the long-term storage condition of unused products before board mounting. The operating temperature and humidity ranges apply to non-energized state after board mounting.

## Materials / Finish

Part	Materials	Color/finish	Remarks
Insulator	LCP	Gray	UL94V-0
		Black	
Contact	Phosphor bronze	Gold-plating	-----
Metal Parts	Brass	Pure tin reflow plating	

## Product Number Structure

**FH** **55** **M** - **40S** - **0.5** **SH**

①      ②      ③      ④      ⑤      ⑥

① Series name : FH	④ Number of contacts : 10 to 61 positions (0.5mm pitch products) 19 to 79 positions (0.4mm pitch products)
② Series No. : 55	
③ No symbol : 0.5mm pitch products M : 0.4mm pitch products	⑤ Contact pitch : 0.5mm or 0.4mm
	⑥ Contact Form SH : SMT horizontal mounting type

May.1.2016 Copyright 2016 HIROSE ELECTRIC CO., LTD. All Rights Reserved.

## Connector dimensional drawing

### ●0.5mm/0.4mm pitch products

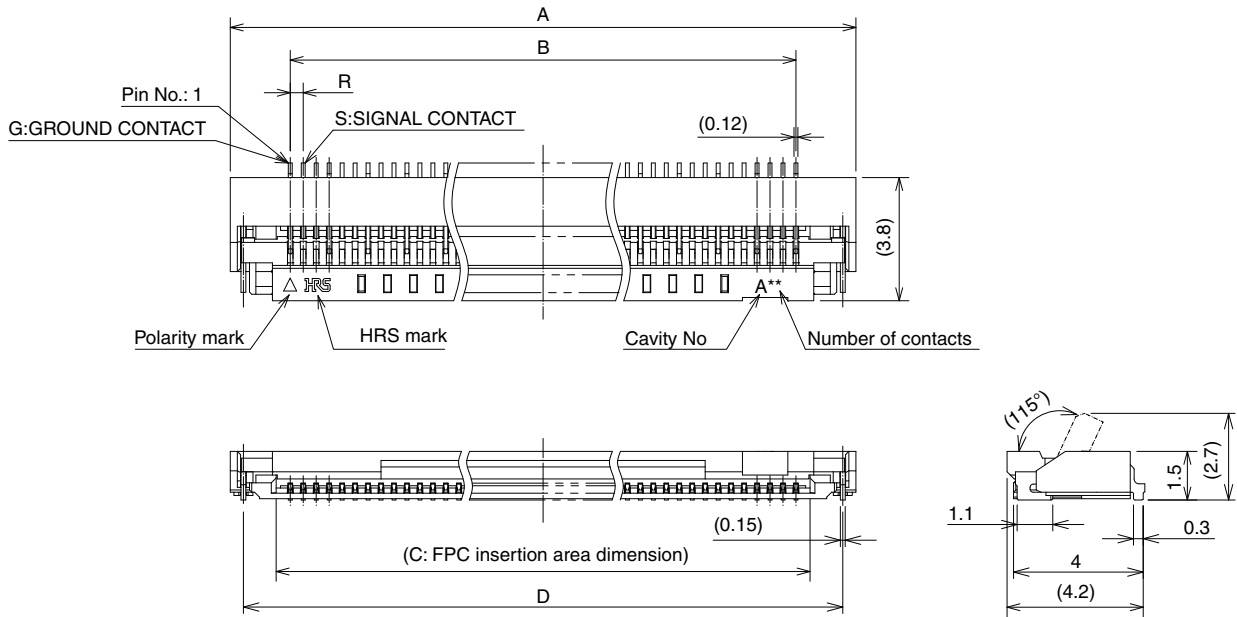

- Notes : 1. The dimensions in parentheses ( ) are reference values.  
 2. The lead co-planarity of connector and reinforcing metal part is MAX 0.1mm.  
 3. This product is emboss-packaged. See the package specification diagram for details.  
 4. Dimensions may be changed for sink mark prevention due to improvement, etc.  
 5. Black dots, etc. may occur in mold resin but do not create a quality problem.  
 6. This product is the halogen-free product. (Br content rate: 900 ppm or less ; Cl content rate : 900ppm or less; Br + Cl total content rate : 1,500ppm or less)  
 7. See the table below for available pin arrangements.  
 S : SIGNAL CONTACT G : GROUND CONTACT  
 \* Pins are arranged in the sequence of GSSG to manage high-speed differential signals ; however, all contacts can be used as signals for normal signals other than high-speed signals. Please contact our sales representative for any questions.

Pin No.	1	2	3	4	5	6	7	8	9	10	11	12	13	14	15	16	17	18	19	20	21	22	23	24	25	26	27	28	29	30	31	32	33	34	35			
Pin assignment	G	S	S	G	S	S	G	S	S	G	S	S	G	S	S	G	S	S	G	S	S	G	S	S	G	S	S	G	S	S	G	S	S	G	S	S	G	S
	36	37	38	39	40	41	42	43	44	45	46	47	48	49	50	51	52	53	54	55	56	57	58	59	60	61	62	63	64	65	66	67	68	69	70			
	S	G	S	S	G	S	S	G	S	S	G	S	S	G	S	S	G	S	S	G	S	S	G	S	S	G	S	S	G	S	S	G	S	S	G	S	S	G
	71	72	73	74	75	76	77	78	79																													
	S	S	G	S	S	G	S	S	G																													

Unit : mm

Part No.	HRS No.	No. of contacts	No. of signal contacts	No. of ground contacts	A	B	C	D	R
FH55-10S-0.5SH	Under planning	10	6	4	8.4	4.5	5.57	7.59	0.5
FH55-22S-0.5SH	580-3707-7 00	22	14	8	14.4	10.5	11.57	13.59	
FH55-31S-0.5SH	580-3704-9 00	31	20	11	18.9	15	16.07	18.09	
FH55-40S-0.5SH	580-3700-8 00	40	26	14	23.4	19.5	20.57	22.59	
FH55-49S-0.5SH	Under planning	49	32	17	27.9	24	25.07	27.09	
FH55-61S-0.5SH	Under planning	61	40	21	33.9	30	31.07	33.09	
FH55M-19S-0.4SH	Under planning	19	12	7	10.9	7.2	8.07	10.09	0.4
FH55M-31S-0.4SH	580-3711-0 00	31	20	11	15.7	12	12.87	14.89	
FH55M-40S-0.4SH	580-3706-4 00	40	26	14	19.3	15.6	16.47	18.49	
FH55M-49S-0.4SH	Under planning	49	32	17	22.9	19.2	20.07	22.09	
FH55M-61S-0.4SH	Under planning	61	40	21	27.7	24	24.87	26.89	
FH55M-79S-0.4SH	Under planning	79	52	27	34.9	31.2	32.07	34.09	

The products above without a HRS No. are currently under planning. Please contact our sales representative for questions concerning the number of contacts.

### Recommended PCB mounting pattern

#### ●FH55 Series

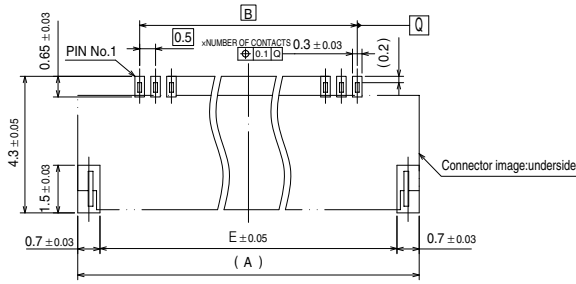

#### ●FH55M Series

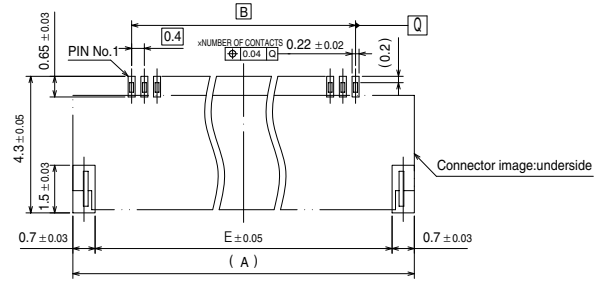

### Recommended Stencil pattern

#### ●FH55 Series

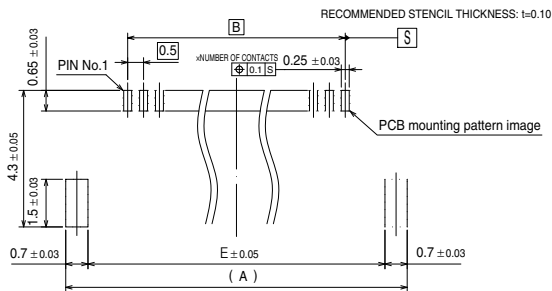

#### ●FH55M Series

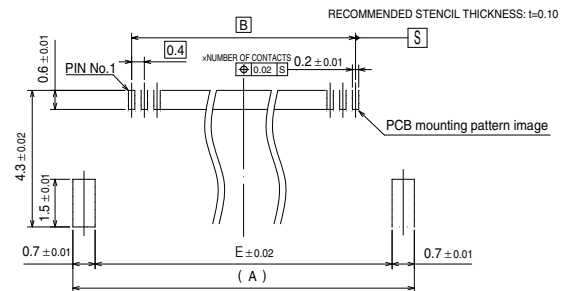

### Recommended FPC dimensional drawing

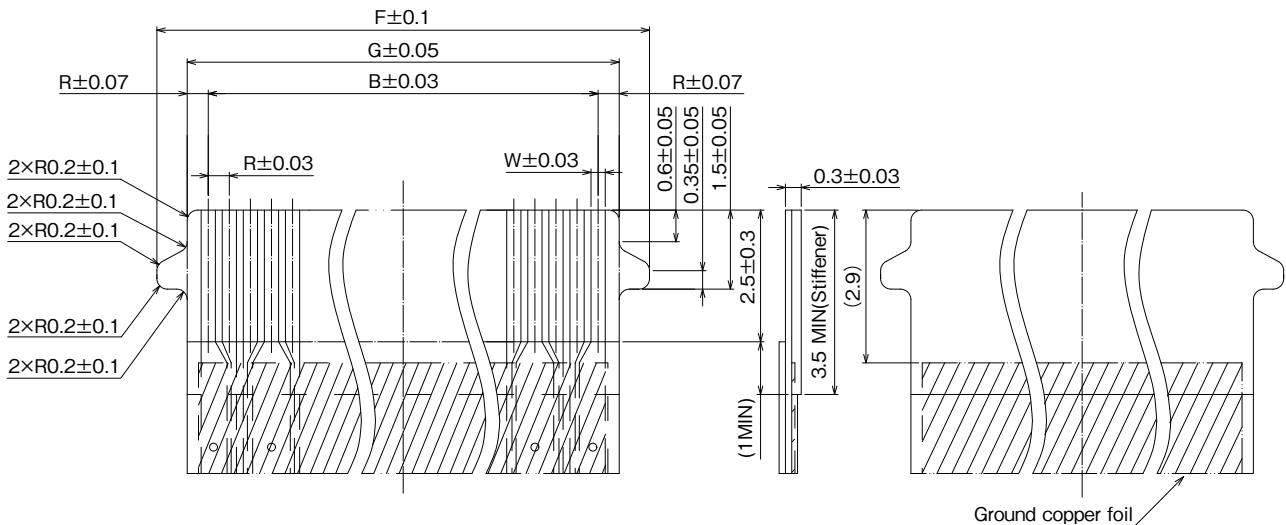

Unit : mm

Part No.	HRS No.	No. of contacts	No. of signal contacts	No. of ground contacts	E	F	G	R	W
FH55-10S-0.5SH	Under planning	10	6	4	7	6.65	5.5	0.5	0.37
FH55-22S-0.5SH	580-3707-7 00	22	14	8	13	12.65	11.5		
FH55-31S-0.5SH	580-3704-9 00	31	20	11	17.5	17.15	16		
FH55-40S-0.5SH	580-3700-8 00	40	26	14	22	21.65	20.5		
FH55-49S-0.5SH	Under planning	49	32	17	26.5	26.15	25		
FH55-61S-0.5SH	Under planning	61	40	21	32.5	32.15	31		
FH55M-19S-0.4SH	Under planning	19	12	7	9.5	9.15	8	0.4	0.27
FH55M-31S-0.4SH	580-3711-0 00	31	20	11	14.3	13.95	12.8		
FH55M-40S-0.4SH	580-3706-4 00	40	26	14	17.9	17.55	16.4		
FH55M-49S-0.4SH	Under planning	49	32	17	21.5	21.15	20		
FH55M-61S-0.4SH	Under planning	61	40	21	26.3	25.95	24.8		
FH55M-79S-0.4SH	Under planning	79	52	27	33.5	33.15	32		

The products above without a HRS No. are currently under planning. Please contact our sales representative for questions concerning the number of contacts.

## FH55/FH55M Series FPC Material Constitution (Recommended Specifications)

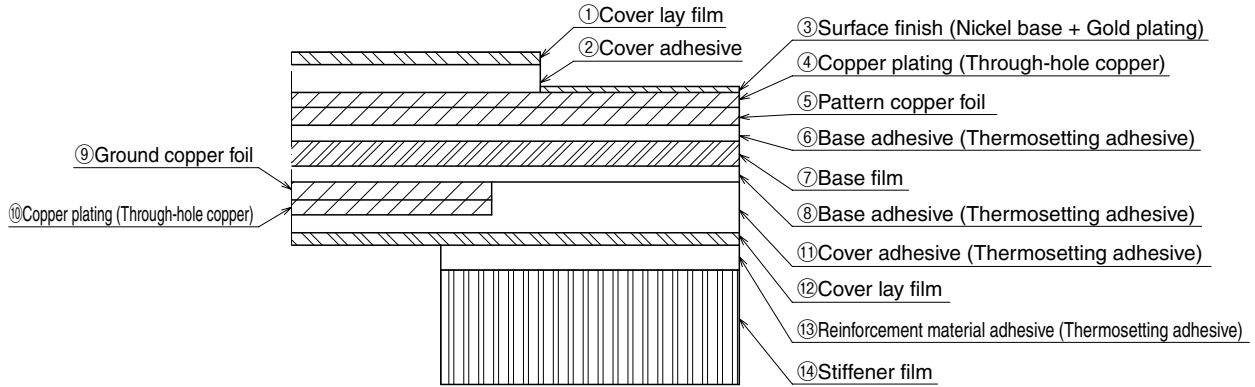

Names of Materials	Material Thickness ( $\mu\text{m}$ )		
	LCP 2-layer CCL	PI 2-layer CCL	PI 3-layer CCL
① Cover lay film	12.5	12.5	12.5
② Cover adhesive	28	28	28
③ Surface treatment (nickel base + gold plating)	(6)	(6)	(6)
④ Copper plating (through-hole copper)	15	15	15
⑤ Pattern copper foil	9	18	18
⑥ Base adhesive	-	-	16
⑦ Base film $\triangleleft$ 2	50	25	25
⑧ Base adhesive	-	-	16
⑨ Ground copper foil	9	18	18
⑩ Copper plating (through-hole copper)	15	15	15
⑪ Cover adhesive	28	28	28
⑫ Cover lay film	12.5	12.5	12.5
⑬ Reinforcement material adhesive (Thermosetting adhesive)	50	50	30
⑭ Stiffener film	125	150	125
Total (Mating Area Thickness: Total of ③~⑧ and ⑪~⑭)	295.5	304.5	291.5

Notes 1 : The FPC material constitution is a reference example. Please make the thickness of FPC mating area  $0.3\pm 0.03$  mm by referring to this material constitution.

② It is a reference example of the base film material. LCP refers to liquid crystal polymer, and PI for polyimide.

## Temperature Profile

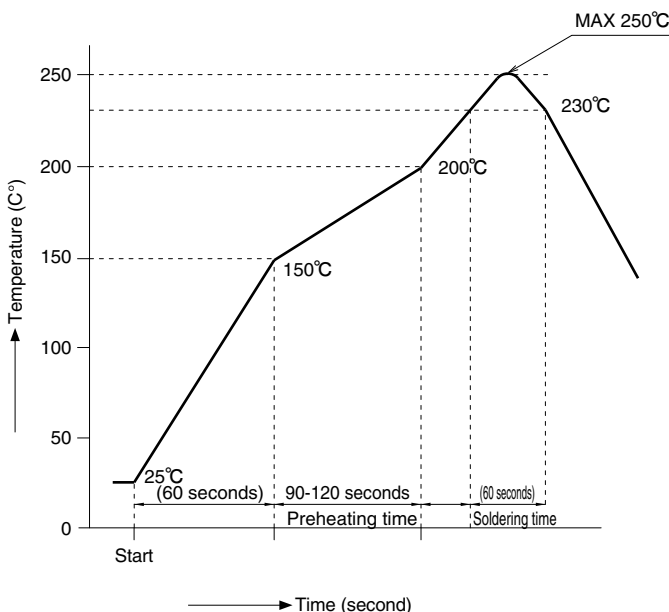

### Applicable Conditions

Reflow System : Far-infrared, hot-air reflow

Reflow chamber atmosphere : Air

Solder : Paste type Sn/3.0Ag/0.5 Cu (M705-221CM5-42-10.5 ; Senju Metal Industry Co., Ltd.)

Test Board : Board material and size  
Glass epoxy 30 x 60 x 1.0mm  
Land dimensions

Contact area: 0.3 x 0.65  
Metal part area: 0.7 x 1.5mm

Metal Mask : Thickness 0.1 mm  
Aperture Dimension  
Contact area 0.25 x 0.65  
Metal part area 0.7 x 1.5mm

The temperature profile shown above is based on the above applicable conditions.

Due to the changing conditions such as solder paste types, manufacturers, board size and other soldering materials, please check to ensure the proper soldering conditions before use.

## Package Specifications

### ● Emboss carrier tape dimensional drawing

(Tape width: 24mm or less)

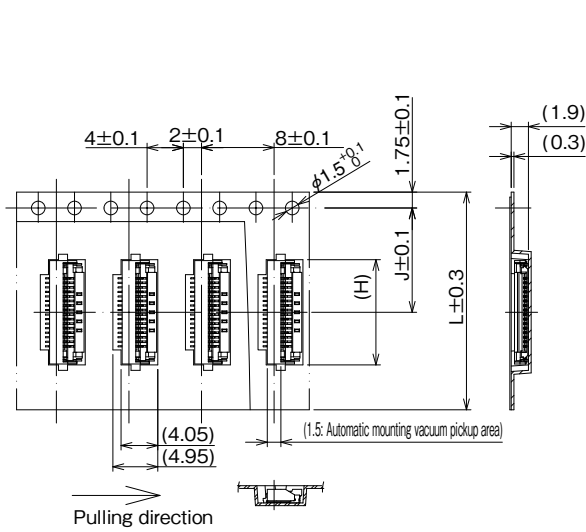

(Tape width: 32mm or more)

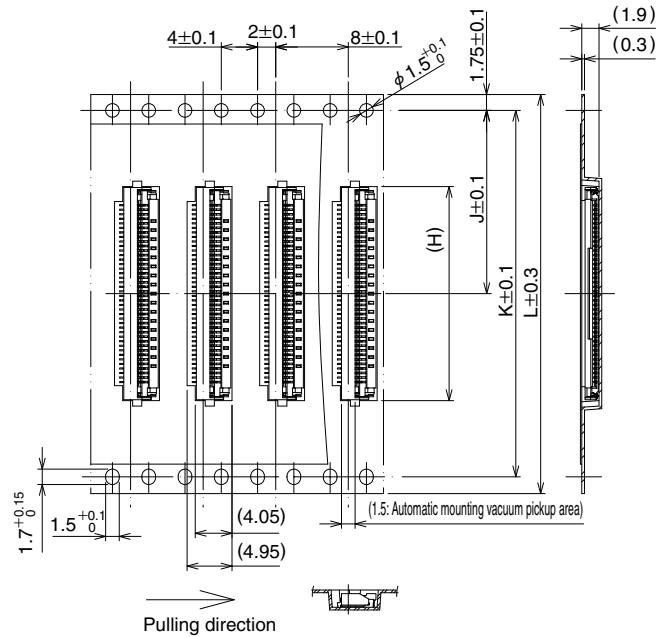

### ● Reel state dimensional drawing

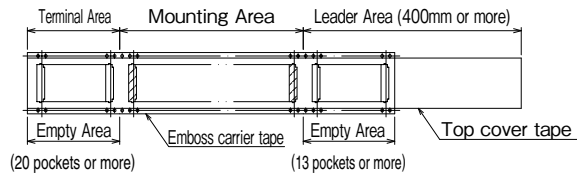
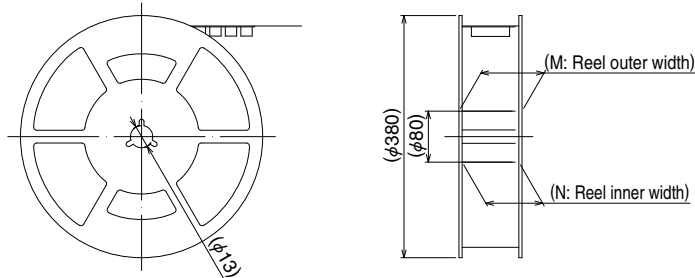

Unit : mm

Part No.	HRS No.	No. of contacts	No. of signal contacts	No. of ground contacts	H	J	K	L	M	N
FH55-10S-0.5SH	Under planning	10	6	4	8.6	11.5	—	24	29.4	25.4
FH55-22S-0.5SH	580-3707-7 00	22	14	8	14.6	11.5	—			
FH55-31S-0.5SH	580-3704-9 00	31	20	11	19.1	14.2	28.4	32	37.4	33.4
FH55-40S-0.5SH	580-3700-8 00	40	26	14	23.6	20.2	40.4			
FH55-49S-0.5SH	Under planning	49	32	17	28.1			26.2	52.4	56
FH55-61S-0.5SH	Under planning	61	40	21	34.1	27.9	52.4			
FH55M-19S-0.4SH	Under planning	19	12	7	11.1			11.5	—	24
FH55M-31S-0.4SH	580-3711-0 00	31	20	11	15.9	14.2	28.4	32	37.4	
FH55M-40S-0.4SH	580-3706-4 00	40	26	14	19.5	20.2	40.4			44
FH55M-49S-0.4SH	Under planning	49	32	17	23.1			26.2	52.4	
FH55M-61S-0.4SH	Under planning	61	40	21	27.9	26.2	52.4			56
FH55M-79S-0.4SH	Under planning	79	52	27	35.1			26.2	52.4	

The products above without a HRS No. are currently under planning. Please contact our sales representative for questions concerning the number of contacts.

## ◆ Operation of Connector and Precautions

### Operation

#### 1. FPC insertion method

- 1 Operate the actuator as it rotates upward and open it. The actuator can be easily operated by flipping it up with a fingernail.

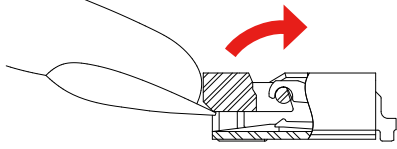

- 2 Insert FPC with its conductor side facing down. There is an FPC position guiding tab. Insert FPC at an angle of approximately 12° against the PCB surface and vertical to the connector. Make sure to insert it completely.

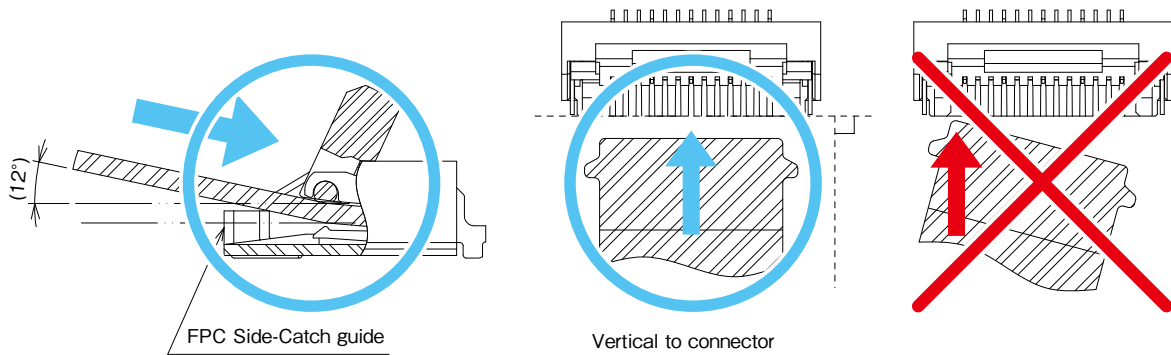

- 3 Operate the actuator in a rotational manner and press it down. When FPC is half inserted or insertion is significantly misaligned, remove the FPC according to the extraction method of 2-1 and operate it again from 1-2. Fix the connector at the time of locking.

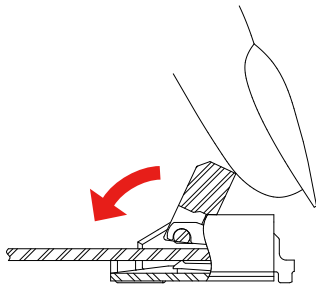

#### 2. FPC Extraction Method

- 1 Operate the actuator upward in a rotational manner by flipping it up and extract FPC after releasing the lock. As there is the FPC position guiding tab, extract the FPC at an angle of approx. 12° against the PCB surface.

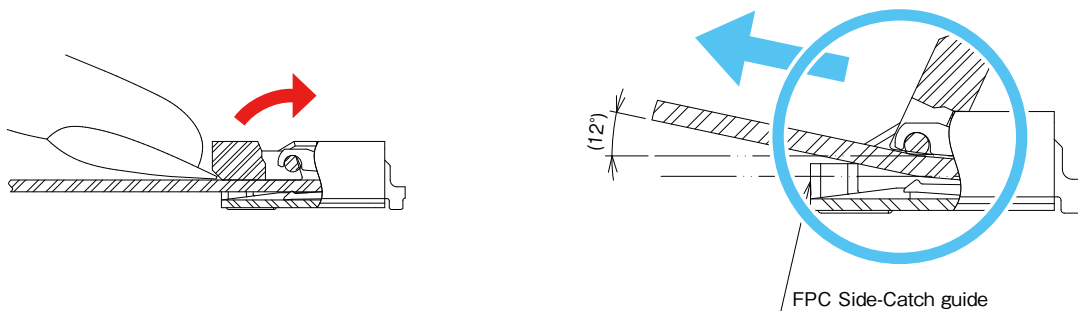

Precautions on Use

As this connector requires careful handling, please check the following points before use. Of note, values described in the precautions are different from the product specification values.

[Precautions at Time of Mounting on PCB]

- ◆PCB Warpage  
Please minimize the PCB warpage amount as much as possible. Although the coplanarity of this connector is 0.1mm or less, mounting failure may occur with an excessive amount of warpage.
- ◆Load to Connector  
Do not to place an excessive external load (1N or less) on the connector before mounting or when removing the emboss package from the reel or when absorbing connectors from the emboss package. Not following these precautions may result in connector breakage. **\*\*Do not insert FPC or operate connector before mounting.\*\***

[Precautions when handling PCB after mounting]

- ◆Load to PCB  
Please do not place load to the PCB in the assembly process when conducting the following, as it may result in connector breakage.
  - Separating the large PCB into individual PCBs
  - Attaching PCB with screws
- ◆Board Bending  
For a board width of 100mm, do not bend the board more than a MAX of 0.5mm (See the diagram below). Bending the board more than 0.5mm may impose that load to the connector and result in breakage.

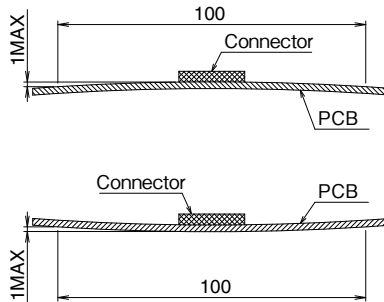

[Precautions when Inserting or Mating the FPC]

Please pay attention to the following points at the time of FPC insertion and mating.

- ◆① Actuator Operation  
When opening the actuator from it's initial state (FPC non-insertion state), please pay attention not to place an excessive amount of force on the actuator. **\*\*Please see the diagram below to prevent deformity of the actuator through finger nail damage.**

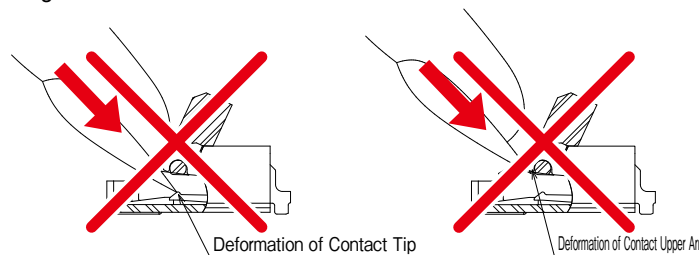

- ◆② As the actuator rotates centering around the shaft as shown in the diagram below, operate it in a rotational manner.

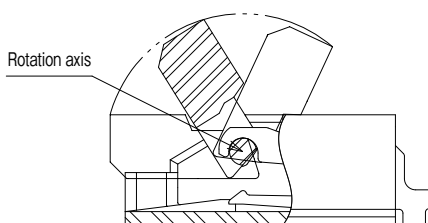



### Precautions on Use

- ③ As the actuator structurally does not open more than 115°, please do not apply force to rotate it further toward back. It may result in disengagement or breakage of the actuator.

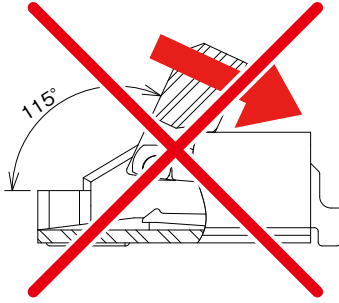

- ④ Operate the actuator in its center area. When closing the actuator while FPC is inserted, operating it at its edge may result in breakage of the actuator or incomplete mating.

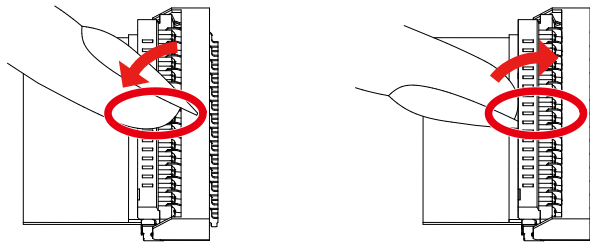

- ⑤ Do not lift the actuator by clipping it or pick it up as shown in the diagrams on the right, as it may result in breakage [Do not perform operations other than the rotational movement described in ④].

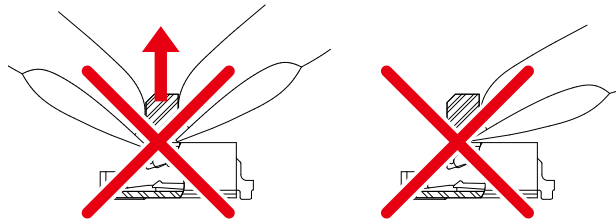

◆ Contact Point Direction

The contact point on this connector is on the bottom; therefore insert the FPC with the conductor exposed surface facing down.

◆ FPC Insertion

- ① There is a FPC position guiding tab. Make sure to completely insert FPC at an angle of approx. 12° against the PCB surface and vertically to the connector. If FPC is inserted at a slant angle, it may result in short circuit failure due to pitch misalignment or contact deformation with the FPC corner getting caught at contacts.

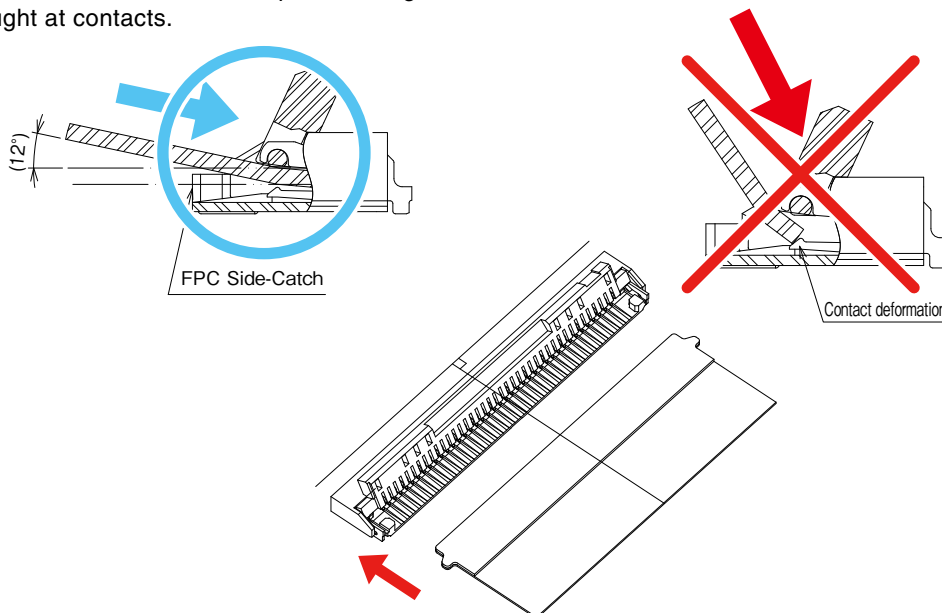

Precautions on Use

- 2 Please do not insert FPC at a markedly slant angle from above. If it is inserted at a markedly slant angle from above in the FPC insertion process as shown in the diagram below, FPC may bend and break the pattern, or insufficient insertion of FPC may result in conduction failure.

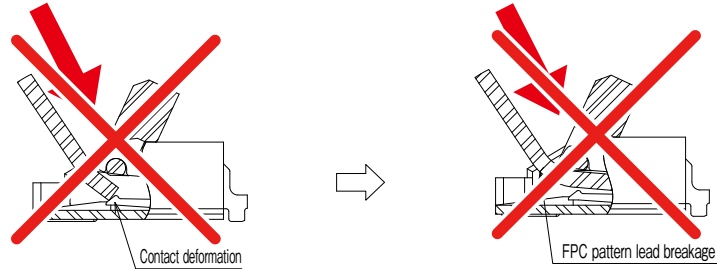

- \* In order to prevent slant insertion of FPC, make sure to secure sufficient space for FPC insertion at the time of layout designing. Insertion will become difficult if FPC is too short, therefore, please design appropriate part layout.
- \* Please confirm details of the flexion and wire breakage of FPC with your FPC manufacturer.

- 3 After FPC insertion, make sure that the FPC position guiding tab is not on top of the FPC position guide on both sides of the connector. Contact failure may occur if the actuator is locked while the FPC position guiding tab is still on top of the FPC position guide.

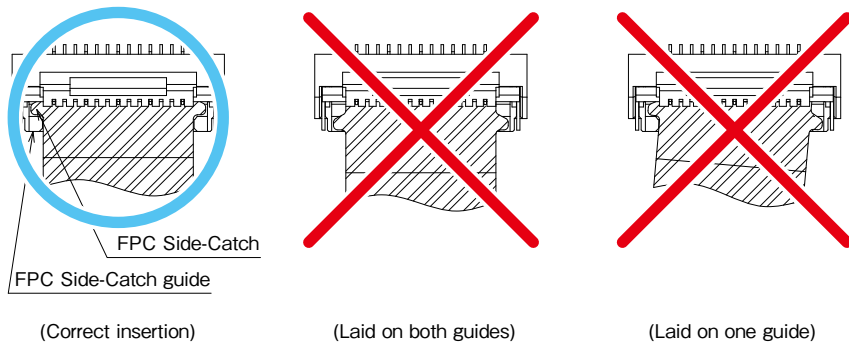

◆ Lock State Confirmation

At the time of locking, make sure that the actuator is parallel to the PCB surface. However, when the actuator gets close to 0°, make sure you use the appropriate amount of force as the use of excessive force, may result in contact deformation (1N or less).

[Precautions when Routing FPC after FPC Insertion]

◆ About the load on the FPC

After the FPC has been inserted, ensure that no load will be applied to the FPC. Bending the FPC at a position near the connector may cause contact failure or FPC lead breakage/damage. In particular, fix the FPC when load is continuously applied to it. Do not bend the FPC sharply near the FPC insertion slot at the time of routing the FPC.

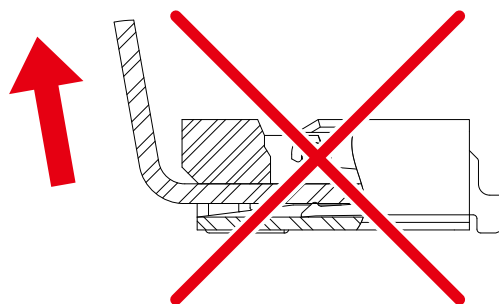

Precautions on Use

**[Precautions when Removing FPC]**

- ◆ Operate the actuator at the center area when releasing it  
If you operate the actuator at its edge when releasing the lock while the FPC is inserted, it may result in actuator breakage.
- ◆ Extracting the FPC while the actuator is unlocked.  
Since these connectors have FPC position guiding tabs, extract the FPC at an angle of 12° against the PCB.

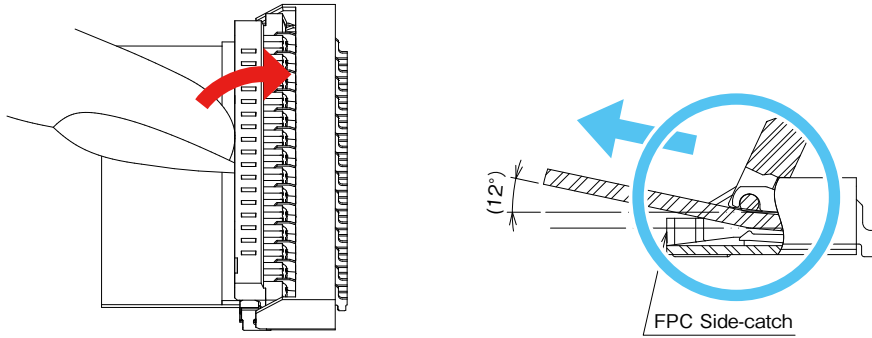

**[Other Precautions]**

- ◆ Hand Soldering Precautions  
When hand soldering for repair, etc.:
  - ① Do not perform reflow or hand soldering with the FPC inserted in the connector.
  - ② Do not apply excessive heat and make sure that the soldering iron does not touch anywhere other than the connector lead. It may result in connector deformation or melting.
  - ③ Do not supply excessive solder (flux).  
If an excessive amount of solder (flux) is supplied to the contact, solder or flux may adhere to the contact points or the shaft of the actuator and can result in contact failure or rotational performance failure of the actuator

May.1.2016 Copyright 2016 HIROSE ELECTRIC CO., LTD. All Rights Reserved.

**USA:**

**HIROSE ELECTRIC (U.S.A.), INC. HEADQUARTERS**  
2300 Warrenville Road, Suite 150,  
Downers Grove, IL 60515  
Phone : +1-630-282-6700  
<http://www.hirose.com/us/>

**USA:**

**HIROSE ELECTRIC (U.S.A.), INC. SAN JOSE OFFICE**  
2841 Junction Ave, Suite 200  
San Jose, CA. 95134  
Phone : +1-408-253-9640  
Fax : +1-408-253-9641  
<http://www.hirose.com/us/>

**USA:**

**HIROSE ELECTRIC (U.S.A.), INC. DETROIT OFFICE (AUTOMOTIVE)**  
17197 N. Laurel Park Drive, Suite 253,  
Livonia, MI 48152  
Phone : +1-734-542-9963  
Fax : +1-734-542-9964  
<http://www.hirose.com/us/>

**THE NETHERLANDS:**

**HIROSE ELECTRIC EUROPE B.V.**  
Hogehillweg #8 1101 CC Amsterdam Z-O  
Phone : +31-20-6557460  
Fax : +31-20-6557469  
<http://www.hirose.com/eu/>

**GERMANY:**

**HIROSE ELECTRIC EUROPE B.V. GERMAN BRANCH**  
Herzog-Carl-Strasse 4 D-73760 Ostfildern  
(Scharnhauser Park)  
Phone : +49-711-4560-02-1  
Fax : +49-711-4560-02-299  
<http://www.hirose.com/eu/>

**GERMANY:**

**HIROSE ELECTRIC EUROPE B.V. NUERNBERG OFFICE**  
Muggenhofer Str. 136 90429 Nuernberg  
Phone : +49-911 32 68 89 63  
Fax : +49-911 32 68 89 69  
<http://www.hirose.com/eu/>

**GERMANY:**

**HIROSE ELECTRIC EUROPE B.V. HANOVER OFFICE**  
Bayernstr. 3, Haus C 30855 Langenhagen, Germany  
Phone : +49-511 97 82 61 30  
Fax : +49-511 97 82 61 35  
<http://www.hirose.com/eu/>

**FRANCE:**

**HIROSE ELECTRIC EUROPE B.V. PARIS OFFICE**  
Regus La Garenne Colombes, Place de La Belgique,  
71 Boulevard National La Garenne Colombes, 92250, France  
Phone : +33 (0) 1 7082 3170  
Fax : +33 (1) 7082 3101  
<http://www.hirose.com/eu/>

**UNITED KINGDOM:**

**HIROSE ELECTRIC EUROPE BV (UK BRANCH)**  
4 Newton Court, Kelvin Drive, Knowlhill,  
Milton Keynes, MK5 8NH  
Phone : +44-1908 202050  
Fax : +44-1908 202058  
<http://www.hirose.com/eu/>

**CHINA:**

**HIROSE ELECTRIC (SHANGHAI) CO., LTD.**  
1601, Henderson Metropolitan, NO.300, East Nanjing  
Road, Huangpu District, Shanghai, China 200001  
Phone : +86-21-6391-3355  
Fax : +86-21-6391-3335  
<http://www.hirose.com/cn/>

**CHINA:**

**HIROSE ELECTRIC (SHANGHAI) CO.,LTD. BEIJING BRANCH**  
A1001, Ocean International Center, Building 56# East 4th  
Ring Middle Road, ChaoYang District, Beijing, 100025  
Phone : +86-10-5165-9332  
Fax : +86-10-5908-1381  
<http://www.hirose.com/cn/>

**CHINA:**

**HIROSE ELECTRIC TECHNOLOGIES (SHENZHEN) CO., LTD.**  
Room 09-13, 19/F, Office Tower Shun Hing Square, Di Wang Commercial Centre,  
5002 Shen Nan Dong Road, Shenzhen City, Guangdong Province, 518008  
Phone : +86-755-8207-0851  
Fax : +86-755-8207-0873  
<http://www.hirose.com/cn/>

**HONG KONG:**

**HIROSE ELECTRIC HONGKONG TRADING CO., LTD.**  
Room 1001, West Wing, Tsim Sha Tsui Centre, 66  
Mody Road, Tsim Sha Tsui East, Kowloon, Hong Kong  
Phone : +852-2803-5338  
Fax : +852-2591-6560  
<http://www.hirose.com/hk/>

**TAIWAN:**

**HIROSE ELECTRIC TAIWAN CO., LTD.**  
103 8F, No.87, Zhengzhou Rd., Taipei  
Phone : +886-2-2555-7377  
Fax : +886-2-2555-7350  
<http://www.hirose.com/tw/>

**KOREA:**

**HIROSE KOREA CO., LTD.**  
250, Huimanggongwon-ro, Siheung-si,  
Gyeonggi-do, Korea, 429-849  
Phone : +82-31-496-7000,7124  
Fax : +82-31-496-7100  
<http://www.hirose.co.kr/>

**SINGAPORE:**

**HIROSE ELECTRIC SINGAPORE PTE. LTD.**  
10 Anson Road #26-16, International Plaza  
079903, Singapore  
Phone : +65-6324-6113  
Fax : +65-6324-6123  
<http://www.hirose.com/sg/>

**INDIA:**

**HIROSE ELECTRIC SINGAPORE PTE. LTD. DELHI LIAISON OFFICE**  
Office NO.519, Regus-Green Boulevard, Level5, Tower C,  
Sec62, Plot B-9A, Block B, Noida, 201301, Uttar Pradesh, India  
Phone : +91-12-660-8018  
Fax : +91-120-4804949  
<http://www.hirose.com/sg/>

**INDIA:**

**HIROSE ELECTRIC SINGAPORE PTE. LTD. BANGALORE LIAISON OFFICE**  
Unit No-403, 4th Floor, No-84, Barton Centre, Mahatma  
Gandhi (MG) Road, Bangalore 560 001, Karnataka, India  
Phone : +91-80-4120 1907  
Fax : +91-80-4120 9908  
<http://www.hirose.com/sg/>

**MALAYSIA:**

**HIROSE ELECTRIC MALAYSIA PTE. LTD.**  
1-10-07, Suntech @ Penang Cybercity (1164),Lintang  
Mayang Pasir 3,11950, Bayan Baru, Penang, Malaysia.  
Phone : +604-619-2564  
Fax : +604-619-2574  
<http://www.hirose.com/sg/>

**THAILAND:**

**BANGKOK OFFICE (REPRESENTATIVE OFFICE)**  
Unit 4703, 47th FL., 1 Empire Tower, South Sathorn  
Road, Yannawa, Sathorn, Bangkok 10120 Thailand  
Phone : +66-2-686-1255  
Fax : +66-2-686-3433  
<http://www.hirose.com/sg/>



**HIROSE ELECTRIC CO.,LTD.**

2-6-3,Nakagawa Chuoh,Tsuzuki-Ku,Yokohama-Shi 224-8540,JAPAN  
TEL: +81-45-620-3526 Fax: +81-45-591-3726  
<http://www.hirose.com>  
<http://www.hirose-connectors.com>

May.1.2016 Copyright 2016 HIROSE ELECTRIC CO., LTD. All Rights Reserved.