

# Subminiature Coaxial Switch 0.85 mm High, DC to 11 GHz

## MS-180 Series

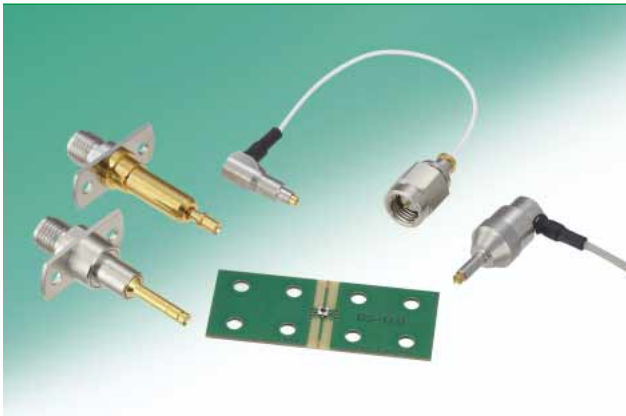

### Overview

Developed for inspection of high frequency circuits used in portable terminals. Verification of the circuit performance is accomplished by simply inserting the external plug in the board mounted receptacle. This action re-directs the circuit from normal condition to the plug side. Removing the plug restores circuit to its normal condition.

The plug connector has been also downsized and the diameter made slimmer than previous products, to give the test tool layout a degree of freedom.

### Features

#### 1. Low insertion loss

- 0.1 dB Max. up to 3.0 GHz (not mated with the plug).
- 0.2 dB Max. up to 6 GHz (not mated with the plug).
- 0.3 dB Max. up to 11 GHz (not mated with the plug).

#### 2. Space-saving and low profile design

- 0.85mm high above the board.
- 1.8mm x 1.8mm occupied board space.

#### 3. Performs over a wide frequency range

Applicable frequencies range over a wide band, from DC to 11 GHz.

#### 4. Miniaturization of the non-implementable area and set aperture hole

The external diameter of the plug tip is as narrow as  $\phi 2.24\text{mm}$ , the non-implementable area and set aperture hole can be minimized.

#### 5. Automatic board placement

Packaged on tape-and-reel the receptacles can be placed with vacuum nozzles of the automatic placement equipment.

#### 6. Beryllium Free, Halogen Free

Chlorine, and bromine are not used in the receptacles.  
 \*Definition according to IEC 61249-2-21.  
 Br 900 ppm max., Cl 900 ppm max., and Br + Cl 1500 ppm max.

### Space-saving design

Low profile -0.85mm protrusion above the board.  
 Small space-1.8mm x 1.8mm occupied board space.

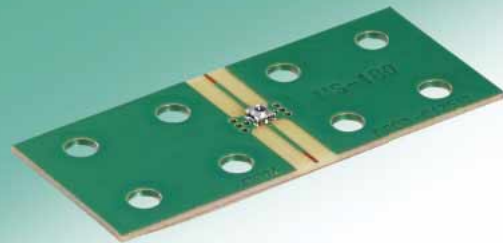

### Size comparison with the existing MS-156C

#### ● Top view

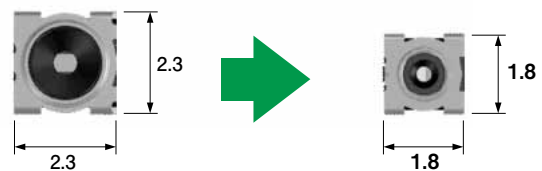

38.7% saving of space

#### ● Height



37% lower profile

#### ● Weight

0.016g → 0.007g

56.3% lighter weight

## Specifications

Operating temperature range	-40°C to +85°C	
Rated power	2W	
Frequency range	DC to 11 GHz Not mated with the plug	DC to 8 GHz Mated (MS-180-HRMJ-3)
V.S.W.R.	1.2 max. (DC to 3.0 GHz)	1.2 max. (DC to 3.0 GHz)
	1.3 max. (3.0 GHz to 6.0 GHz)	1.3 max. (3.0 to 8.0 GHz)
	1.4 max. (6.0 GHz to 11.0 GHz)	
Insertion loss	0.1 dB max. (DC to 3.0 GHz)	0.3 dB max. (DC to 3.0 GHz)
	0.2 dB max. (3.0 GHz to 6.0 GHz)	0.5 dB max. (3.0 GHz to 6.0 GHz)
	0.3 dB max. (6.0 GHz to 11.0 GHz)	0.6 dB max. (6.0 GHz to 8.0 GHz)
Isolation	25 dB min. (DC to 3.0 GHz)	
	20 dB min. (3.0 GHz to 6.0 GHz)	
	12 dB min. (6.0 GHz to 11.0 GHz)	

Item	Specification	Conditions
1. Contact resistance	100mΩ max.	100mA max.
2. Insulation resistance	1000MΩ min.	100V DC
3. Withstanding voltage	No flashover or insulation breakdown	100 V AC / 1 minute
4. Vibration	No electrical discontinuity of 1 μs or more	Frequency: 10 to 55 Hz, single amplitude of 0.75mm, 10 cycles in each of the 3 axis
5. Shock	No electrical discontinuity of 1 μs or more	Acceleration of 490m/s <sup>2</sup> , 11 ms duration, sine halfwave, 3 cycles in each of the 3 axis
6. Temperature cycle	Contact resistance: 100 mΩ max. Insulation resistance: 10 MΩ min.	Temperature : -55°C → +15°C to +35°C → +85°C → +15°C to +35°C Time: 30 → 2 to 3 → 30 → 2 to 3 minutes 100 cycles
7. High temperature exposure	Contact resistance: 100 mΩ max. Insulation resistance: 10 MΩ min.	96 hours at 85°C
8. Low temperature exposure	Contact resistance: 100 mΩ max. Insulation resistance: 10 MΩ min.	96 hours at -55°C
9. Humidity (Steady state)	Contact resistance: 100 mΩ max. Insulation resistance: 10 MΩ min.	96 hours at 40±2°C and humidity of 90 to 95%
10. Durability	Contact resistance: 100 mΩ max.	100 cycles

## Materials

Part	Material	Finish	Remarks
Shell	Brass	Partially gold plating	—
Insulator	LCP	—	UL94V-0
Common terminal	Copper alloy	Partially gold plating	—
Antenna terminal	Copper alloy	Partially gold plating	—

## Typical Data

### ● NORMALLY CLOSED(Not Mated with the plug)

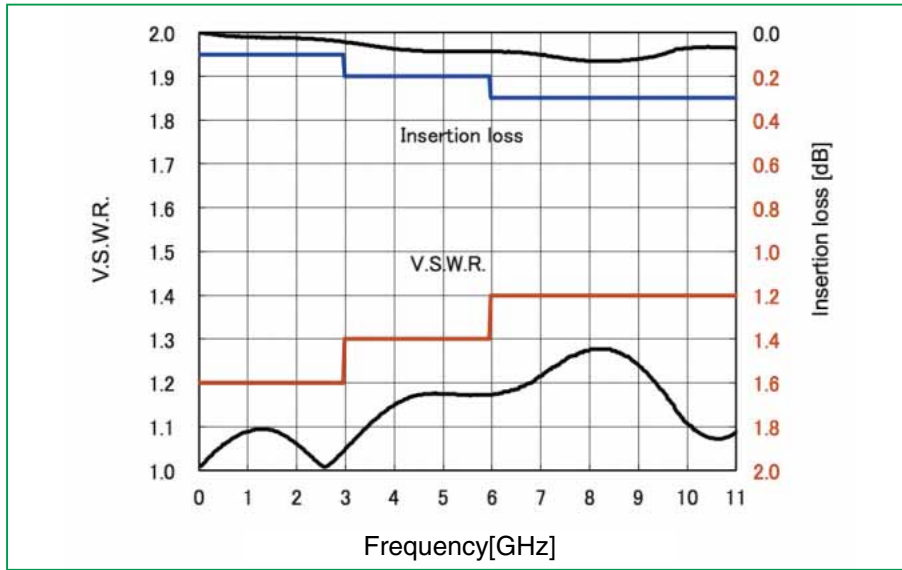

### ● NORMALLY OPEN(Mated with the plug)

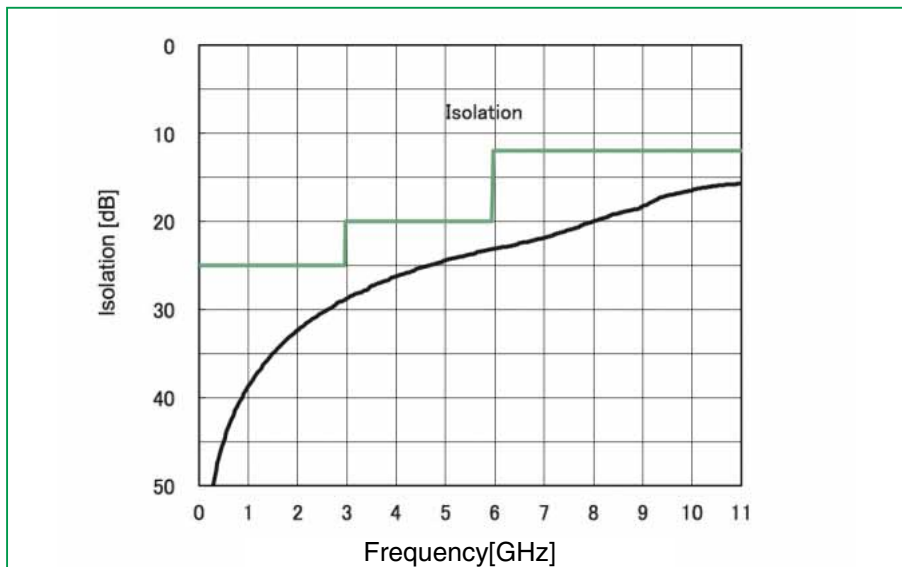
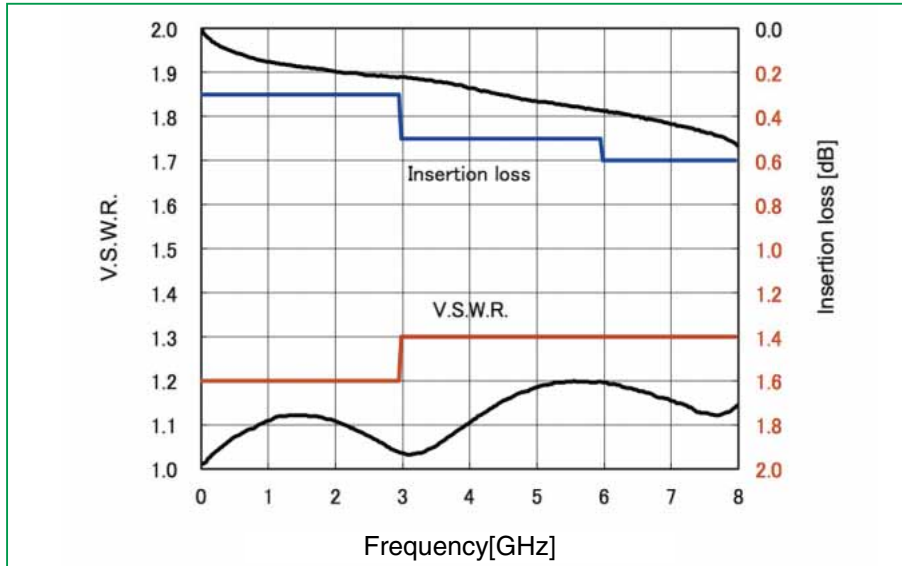

May.1.2016 Copyright 2016 HIROSE ELECTRIC CO., LTD. All Rights Reserved.

## Receptacle

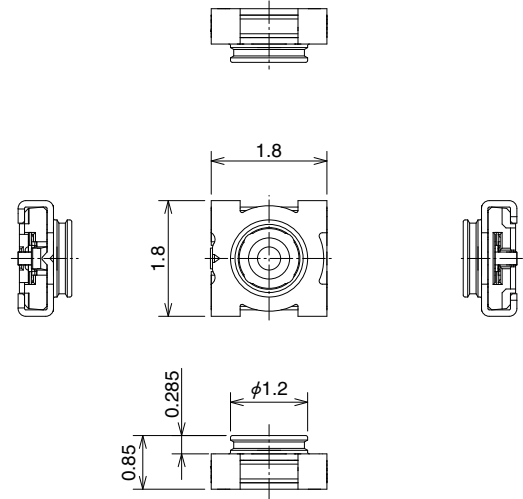

Part No.	HRS No.	Packaging
MS-180	358-0265-7	15,000 pcs/reel
MS-180(20)	358-0265-7 20	3,000 pcs/reel

## Circuit diagram

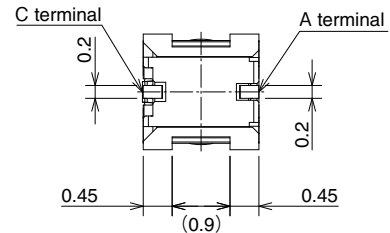
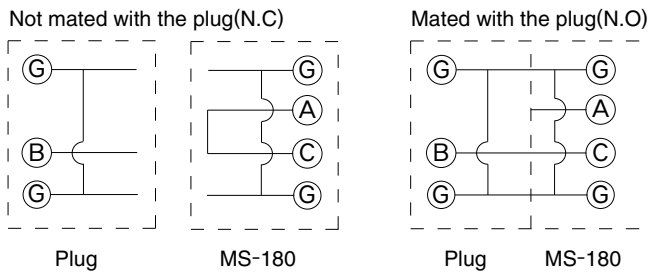

## Specified PCB mounting pattern and metalmask dimensions

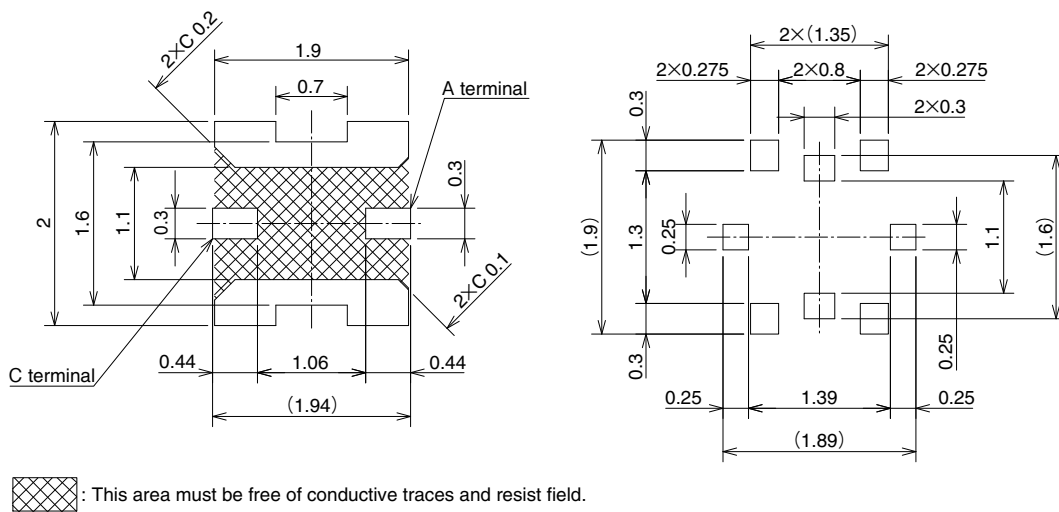

Note. • Please always reflow the product using specified PCB mounting pattern and metalmask dimensions. Otherwise it may cause solder wicking and/or flux penetration affecting the product performance.  
 • Do not use hand soldering for mounting of MS-180 Doing so could result in solder and flux wicking to the contact areas.

## Recommended Temperature Profile

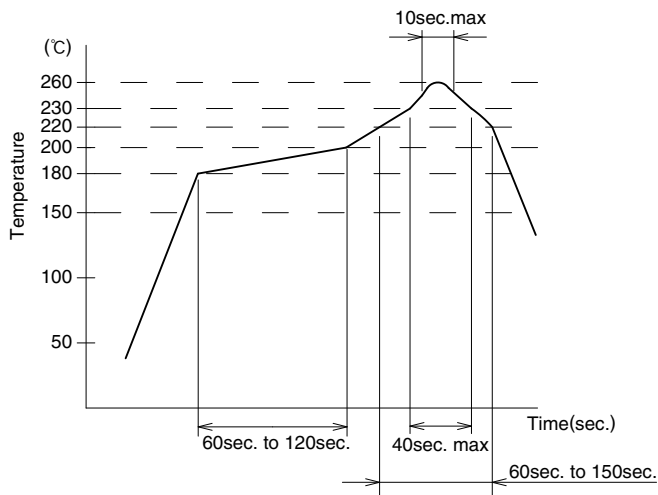

Using Lead-free Solder paste

① Maximum temperature	: 260°C
② Peak temperature time	: 10 sec. max.
③ 230°C min.	: 40 sec. max.
④ 220°C min.	: 60 sec. to 150 sec.
⑤ 180°C to 200°C	: 60 sec. to 120 sec.

Metal mask thickness : 0.1 mm  
Reflow cycles : 2 cycles

## Packaging Specifications

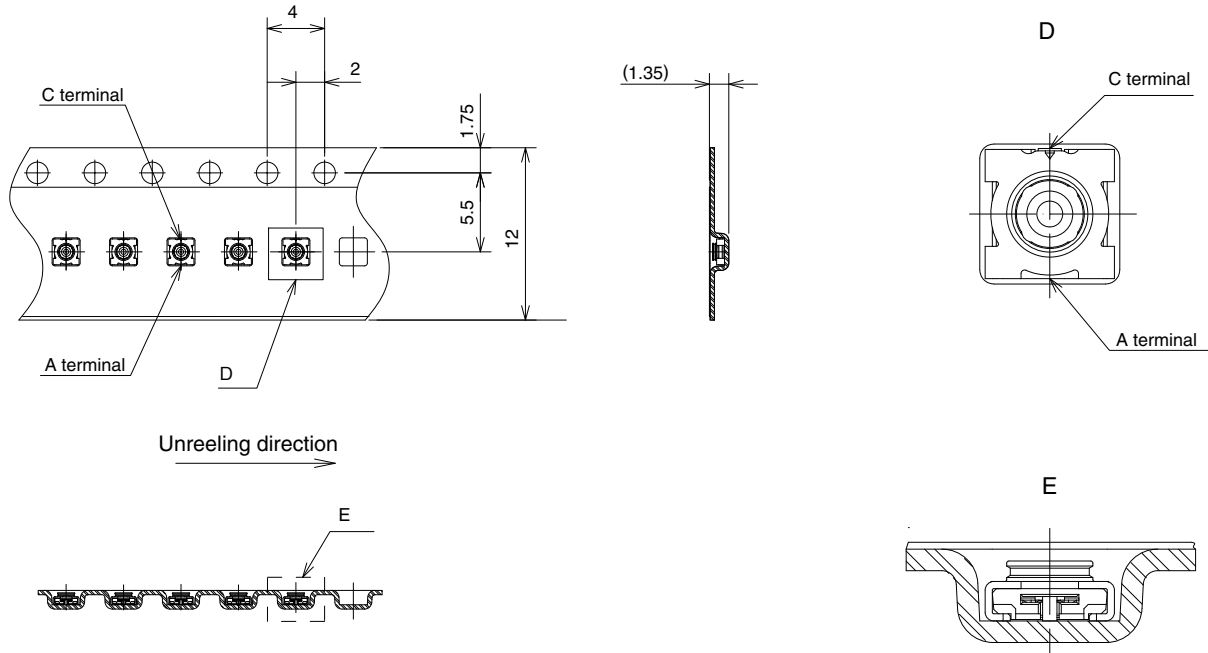

### Reel dimentions

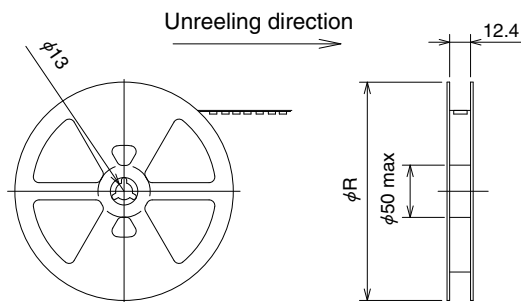

Part No.	Reel size	Packaging
MS-180	φ380mm	15,000 pcs/reel
MS-180(20)	φ180mm	3,000 pcs/reel

## Test adaptors with SMA connection

### ●Rigid body structure with mounting flange (designed for mass production testing)

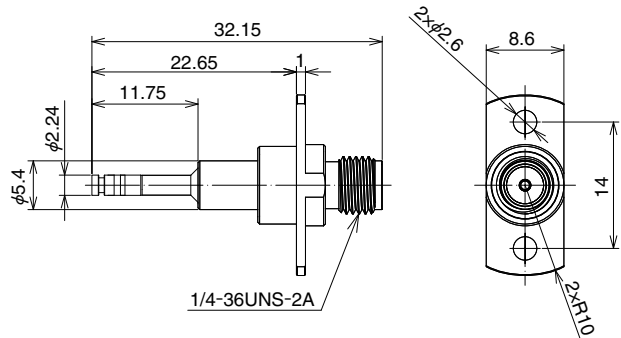

- By using 6-10 N of force, this version will mate vertically with the MS-180 receptacle.
- This durability rating only applies to this specific test adaptor.

Part No.	HRS No.	Durability
MS-180-HRMJ-3	358-0318-1	10,000 cycles

### ●Floating version (Designed for mass production use)

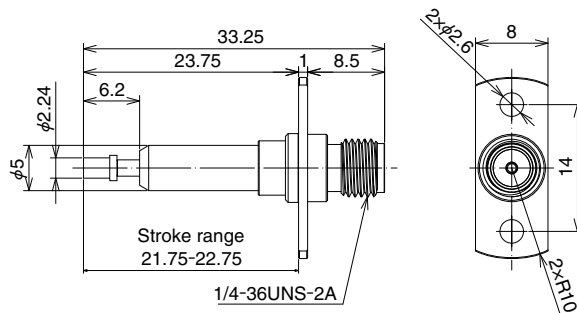

- The test adaptor will mate vertically with the MS-180 receptacle. Please note the specified stroke length.
- This durability rating only applies to this specific test adaptor.

Part No.	HRS No.	Durability
MS-180-HRMJ-F5	358-0321-6	10,000 cycles

## Plugs and Plug Assemblies

### ●Friction locking version (Designed for prototype/manual evaluation use)



- The plugs locking system provides the retention force needed between the plug and the MS-180 receptacle to manually test the application. Vertical mating required for testing.
- This durability rating only applies to this specific plug.
- This product is sold as a complete assembly; please make your selection from the products shown on the right. Customization is available for cable assemblies; please contact your local Hirose Sales Representative for the availability of special cable lengths and other options being offered.

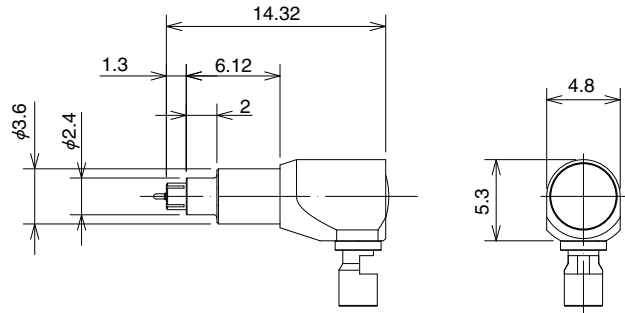

Part No.	HRS No.	Durability
MS-180-040LP-H3	358-0319-4	500 cycles

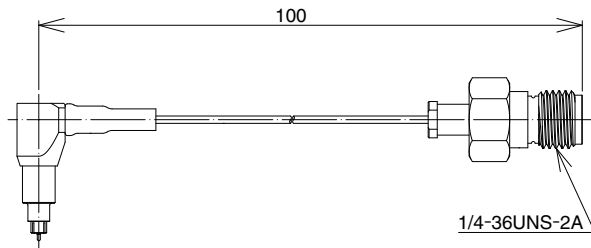

Part No.	HRS No.	Durability
MS180LH3-HRMJ-040V100	362-0224-9 01	500 cycles

### ●Positive locking version (Designed for prototype/manual evaluation use)



- The plug's locking system provides the positive retention force needed between the plug and the MS-180 receptacle to manually test the application. Vertical mating required for testing.
- This durability rating only applies to this specific plug.
- This product is sold as a complete assembly; please make your selection from the products shown on the right. Customization is available for cable assemblies; please contact your local Hirose Sales Representative for the availability of special cable lengths and other options being offered.

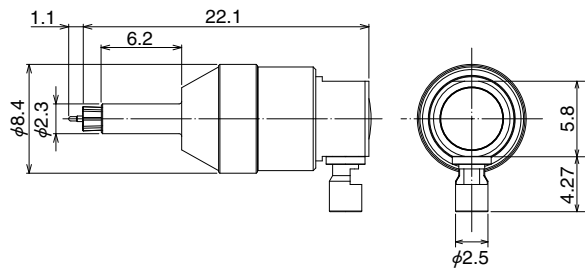

Part No.	HRS No.	Durability
MS-180-088LP-H1	358-0269-8	500 cycles

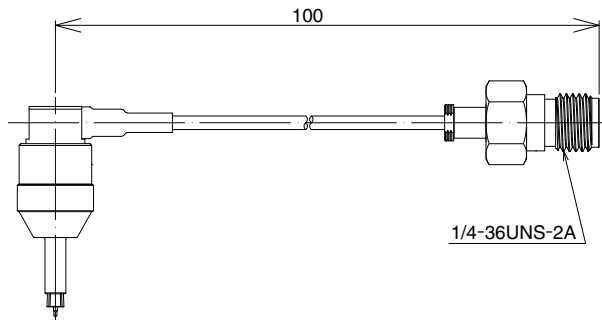

Part No.	HRS No.	Durability
MS180LH1-HRMJ-088V100	362-0223-6 01	500 cycles

May.1.2016 Copyright 2016 HIROSE ELECTRIC CO., LTD. All Rights Reserved.



## ◆ Precautions

1. Do not use the washing process.
2. During the design phase of the device, please make sure that extra force will not be exerted onto this connector in the event that it is dropped.
3. This product is intended to be used for circuit inspection only. Consult us if any other application is considered.
4. Plugs can be roughly classified to two types.  
 For mass production line automatic check (Press down type)  
 For manual check (With retentive lock) : Unable to be used at production line.
5. Do not use hand soldering for mounting of MS-180.  
 Doing so could result in solder and flux wicking to the contact areas.
6. When using a heat gun, hot plate, or similar methods, limit the temperature to 260°C applied for 10 seconds max.
7. Please always reflow the product using specified PCB mounting pattern and metalmask dimensions.  
 Otherwise it may cause solder wicking and/or flux penetration affecting the product performance.
8. Please refrain from using the product in environments specifically affected by dust, high humidity, gases, very high temperatures and very low temperatures.
9. Exercise caution as not to allow any debris to enter the board mounted MS-180 when cutting PCB.

May.1.2016 Copyright 2016 HIROSE ELECTRIC CO., LTD. All Rights Reserved.



## HIROSE ELECTRIC CO.,LTD.

2-6-3,Nakagawa Chuoh,Tsuzuki-Ku,Yokohama-Shi 224-8540,JAPAN  
 TEL: +81-45-620-3526 Fax: +81-45-591-3726  
<http://www.hirose.com>  
<http://www.hirose-connectors.com>