

NOTE:

1. MATERIAL AND FINISH

1.1. SHELL ASSEMBLY: COPPER ALLOY, OUTER SHELL AND COLLET NUT Cr PLATING, OTHER METALLIC COMPONENTS Ni PLATING

1.2. INSULATOR: PEEK

1.3. CONTACT: COPPER ALLOY, GOLD PLATING

2. RoHS COMPLIANCE

3. PCB DRILLING PATTERN ALL VIEWS ARE FROM THE SIDE OF THE SOCKET

4. PART NO.

| No. OF CONTACTS | ∅A  | L   |
|-----------------|-----|-----|
| 02,03           | 0.7 | 3.2 |
| 04,05...08,09   | 0.5 | 3.2 |

R - F 0 B N \* \* 0 \* 0 0 \* 0 0

|                  |
|------------------|
| CONTACT POS.     |
| 02-09=2pin-09pin |

|                |
|----------------|
| SHELL MATERIAL |
| 0=Brass        |

| CODE | KEY ANGLES |
|------|------------|
| 0    | 0          |
| A    | 30°        |
| B    | 60°        |
| ..   | ..         |

| CODE | CONTACT TYPE          |
|------|-----------------------|
| 2    | Male Solder Contact   |
| 4    | Female Solder Contact |
| C    | Crimp Male Contact    |
| M    | Crimp Female Contact  |
| 1    | Male Print Contact    |
| 3    | Female Print Contact  |

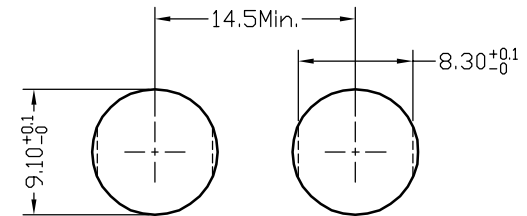

PANEL CUT-OUT

| REV. | DESCRIPTION | DATE     | APPD   |
|------|-------------|----------|--------|
| A    | ECN-150053  | 05/13/15 | Seawen |

|   |  |   |
|---|--|---|
| UNITS<br>■mm □INCH                        | NAME:<br>SNAP LATCH METAL<br>08 FIXED SOCKET | NEXTRONICS ENGINEERING CORP.<br>TITLE:<br>CUSTOMER DWG. |
| GENERAL TOLERANCES:<br>(UNLESS SPECIFIED) | PART NO:<br>R-F0BN**0*00*00                  |   |
| 4 PLACE ±** ±**                           | APPD:Seawen 5/13/15                          | DWG NO:<br>010-0000-B23                                 |
| 3 PLACE ±0.10 ±**                         | CHKD:Peter 5/13/15                           | C   |
| 2 PLACE ±0.30 ±**                         | DRAWN:Alex 5/13/15                           | SCALE: SHEET: REV.:                                     |
| 1 PLACE ±0.50 ±**                         |  | 2.5/1 1/4 A   |
| ANGULAR: X°±2° X°±**                      |  |   |

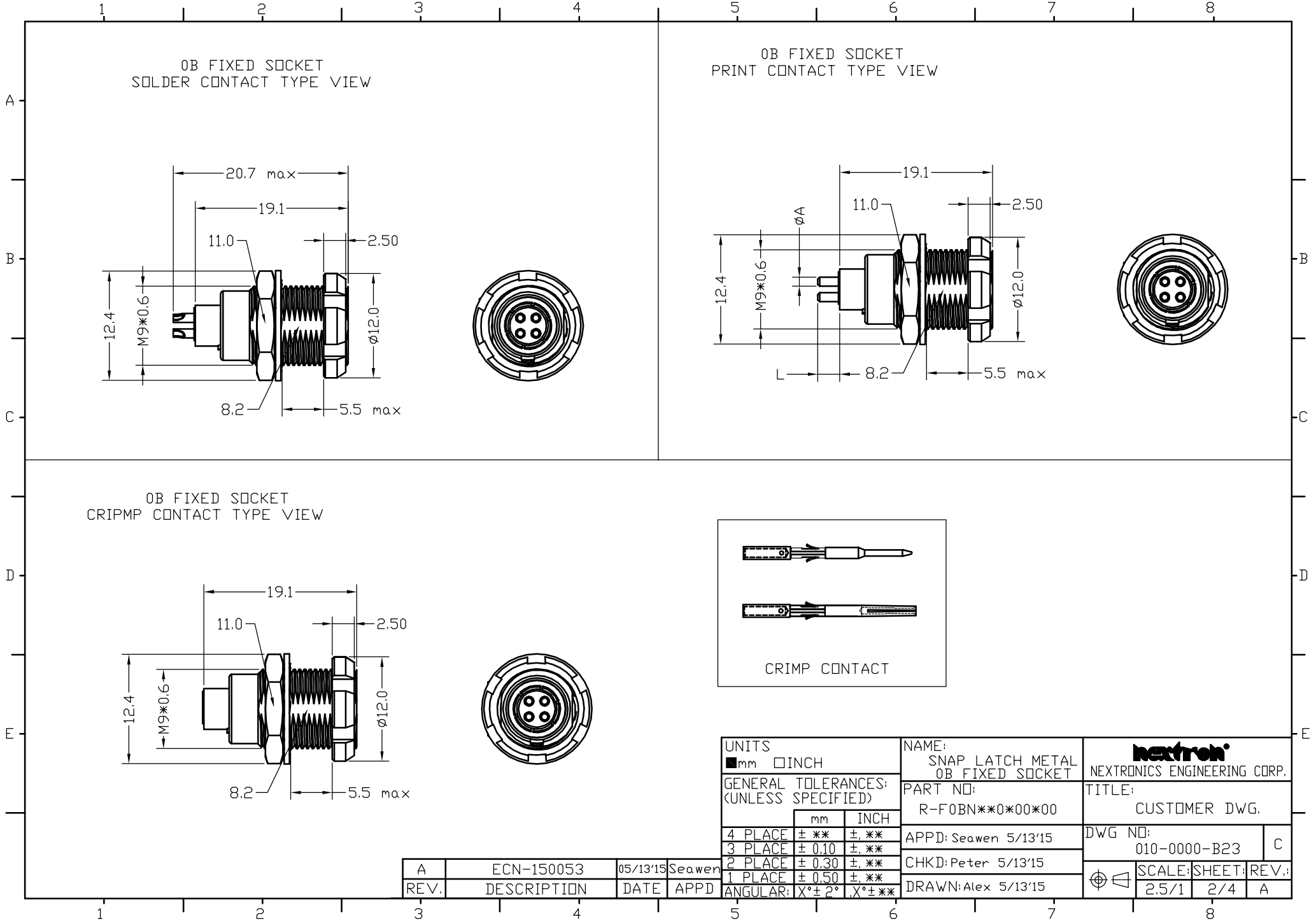

OB FIXED SOCKET  
SOLDER CONTACT TYPE VIEW

OB FIXED SOCKET  
PRINT CONTACT TYPE VIEW

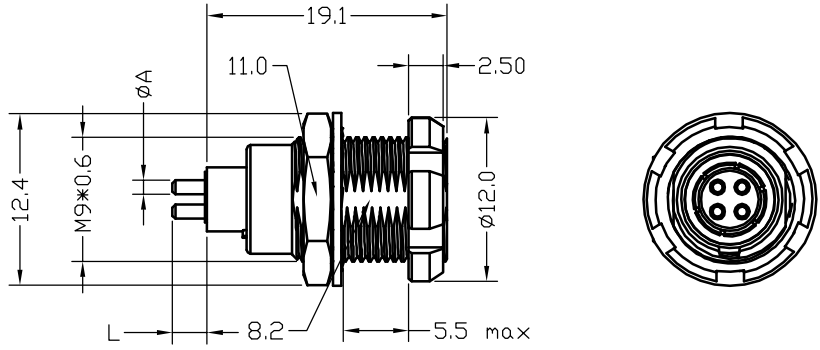
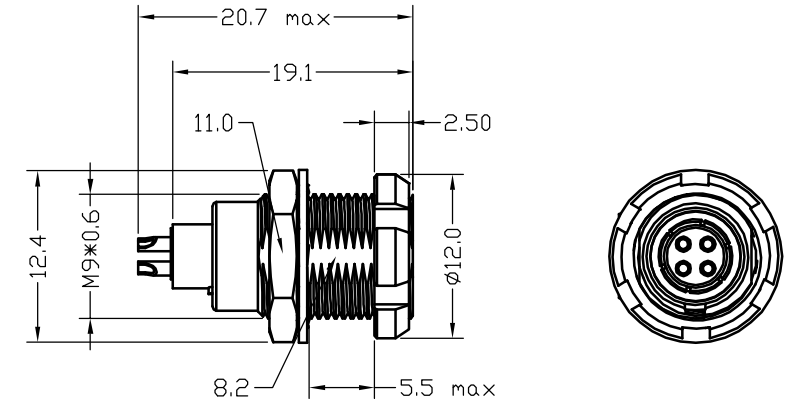

OB FIXED SOCKET  
CRIMP CONTACT TYPE VIEW

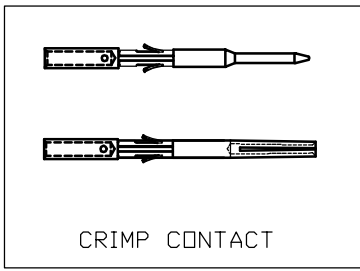
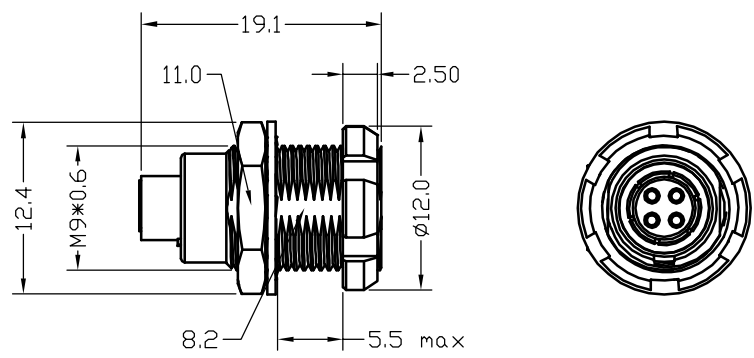

|   |         |  |                      |  |  |
|---|---------|--|----------------------|--|--|
| UNITS<br>■mm □INCH                        |         | NAME:<br>SNAP LATCH METAL<br>OB FIXED SOCKET |                      | NEXTRON®<br>NEXTRONICS ENGINEERING CORP. |  |
| GENERAL TOLERANCES:<br>(UNLESS SPECIFIED) |         | PART NO:<br>R-F0BN**0*00*00                  |                      | TITLE:<br>CUSTOMER DWG.                  |  |
|   | mm      | INCH   | APPD: Seawen 5/13'15 | DWG NO:<br>010-0000-B23                  |  |
| 4 PLACE                                   | ± **    | ± **   | CHKD: Peter 5/13'15  | C  |  |
| 3 PLACE                                   | ± 0.10  | ± **   | DRAWN: Alex 5/13'15  | SCALE: SHEET: REV.:<br>2.5/1 2/4 A       |  |
| 2 PLACE                                   | ± 0.30  | ± **   |                      |  |  |
| 1 PLACE                                   | ± 0.50  | ± **   |                      |  |  |
| ANGULAR:                                  | X° ± 2° | X° ± **                                      |                      |  |  |

|      |             |          |        |
|------|-------------|----------|--------|
| A    | ECN-150053  | 05/13'15 | Seawen |
| REV. | DESCRIPTION | DATE     | APPD   |

KEY ANGLES (RECEPTACLE FRONT VIEW):

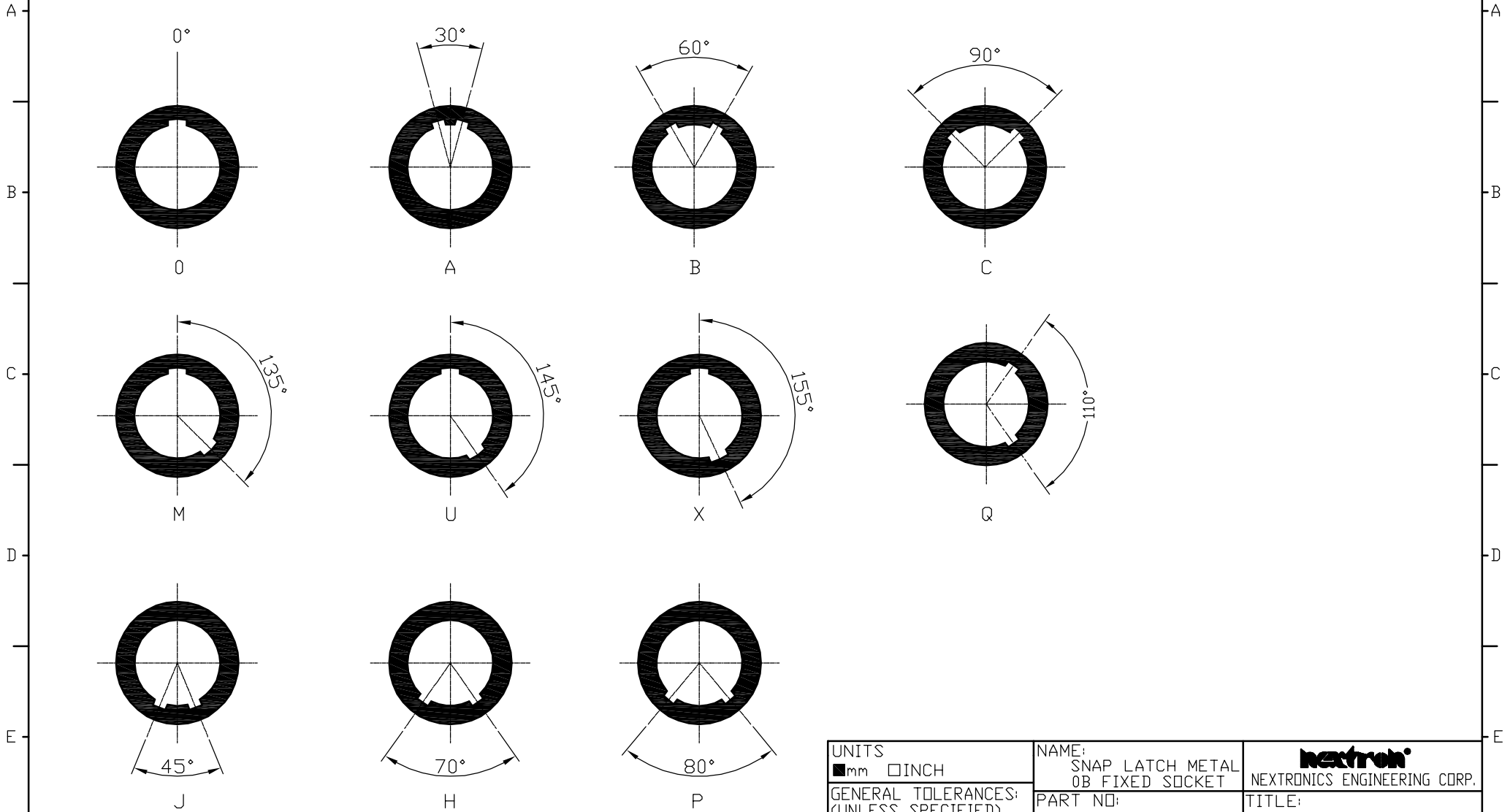

|   |         |  |                      |                              |                         |
|---|---------|--|----------------------|------------------------------|-------------------------|
| UNITS<br>■mm □INCH                        |         | NAME:<br>SNAP LATCH METAL<br>0B FIXED SOCKET |                      | NEXTRONICS ENGINEERING CORP. |                         |
| GENERAL TOLERANCES:<br>(UNLESS SPECIFIED) |         | PART NO:<br>R-F0BN**0*00*00                  |                      | TITLE:<br>CUSTOMER DWG.      |                         |
|   | mm      | INCH   | APPD: Seawen 5/13'15 |                              | DWG NO:<br>010-0000-B23 |
| 4 PLACE                                   | ± **    | ± **   | CHKD: Peter 5/13'15  |                              | C                       |
| 3 PLACE                                   | ± 0.10  | ± **   | DRAWN: Alex 5/13'15  |                              |                         |
| 2 PLACE                                   | ± 0.30  | ± **   |                      |                              |                         |
| 1 PLACE                                   | ± 0.50  | ± **   |                      |                              |                         |
| ANGULAR:                                  | X° ± 2° | X° ± **                                      |                      |                              |                         |

|      |             |         |        |
|------|-------------|---------|--------|
| A    | ECN-150053  | 5/13'15 | Seawen |
| REV. | DESCRIPTION | DATE    | APPD   |

PCB DRILLING PATTERN

02PIN

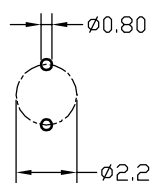

03PIN

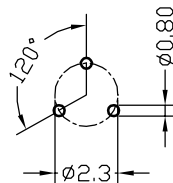

04PIN

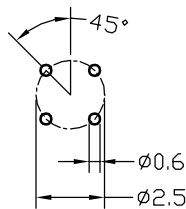

05PIN

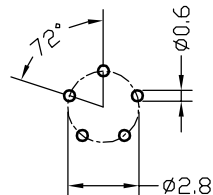

06PIN

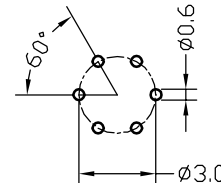

07PIN

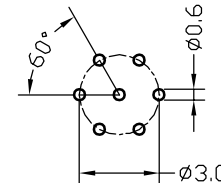

08PIN

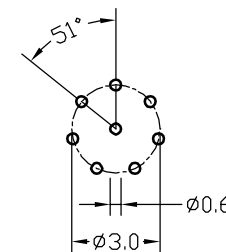

09PIN

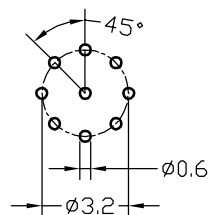

|   |  |  |  |                                    |  |
|---|--|--|--|------------------------------------|--|
| UNITS<br><input checked="" type="checkbox"/> mm <input type="checkbox"/> INCH |  | NAME:<br>SNAP LATCH METAL<br>0B FIXED SOCKET |  | <br>NEXTRONICS ENGINEERING CORP.   |  |
| GENERAL TOLERANCES:<br>(UNLESS SPECIFIED)                                     |  | PART NO:<br>R-F0BN**0*00*00                  |  |                                    |  |
|   |  |  |  | APPD: Seawen 5/13'15               |  |
|   |  |  |  | CHKD: Peter 5/13'15                |  |
|   |  |  |  | DRAWN: Alex 5/13'15                |  |
|   |  | ANGULAR: X°±2° X*±**                         |  | DWG NO:<br>010-0000-B23            |  |
|   |  |  |  | SCALE: SHEET: REV.:<br>2.5/1 4/4 A |  |

|      |             |          |        |
|------|-------------|----------|--------|
| A    | ECN-150053  | 05/13'15 | Seawen |
| REV. | DESCRIPTION | DATE     | APPD   |