

NOTE:

- MATERIAL AND FINISH
 - SHELL ASSEMBLY: COPPER ALLOY, OUTER SHELL AND COLLET NUT Cr PLATING, OTHER METALLIC COMPONENTS Ni PLATING
 - INSULATOR: PEEK
 - CONTACT: COPPER ALLOY, GOLD PLATING
- RoHS COMPLIANCE
- PART NO.

No. OF CONTACTS	øA	L
02,03	0.7	3.2
04,05...08,09	0.5	3.2

R - F 0 B R * * 0 * 0 0 * 0 0

CONTACT POS.	02-09=2pin-09pin
SHELL MATERIAL	0=Brass

CODE	KEY ANGLES
0	0
A	30°
B	60°
"	"

CODE	CONTACT TYPE
2	Male Solder Contact
4	Female Solder Contact
C	Crimp Male Contact
M	Crimp Female Contact
1	Male Print Contact
3	Female Print Contact

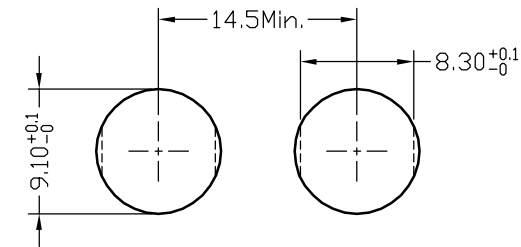

PANEL CUT-OUT

A	ECN-150053	5/13/15	Seawen
REV.	DESCRIPTION	DATE	APPD

UNITS ■mm □INCH	NAME: SNAP LATCH METAL OB FIXED SOCKET	nexttron NEXTRONICS ENGINEERING CORP.	
GENERAL TOLERANCES: (UNLESS SPECIFIED)	PART NO: R-F0BR**0*00*00	TITLE: CUSTOMER DWG.	
4 PLACE ±.**	APPD: Seawen 5/13'15	DWG NO: 010-0000-B22	C
3 PLACE ±0.10 ±.**	CHKD: Peter 5/13'15	SCALE: 2.5/1	SHEET: 1/4
2 PLACE ±0.30 ±.**	DRAWN: Alex 5/13'15	REV.: A	
1 PLACE ±0.50 ±.**			
ANGULAR: X°±2° X'±**			

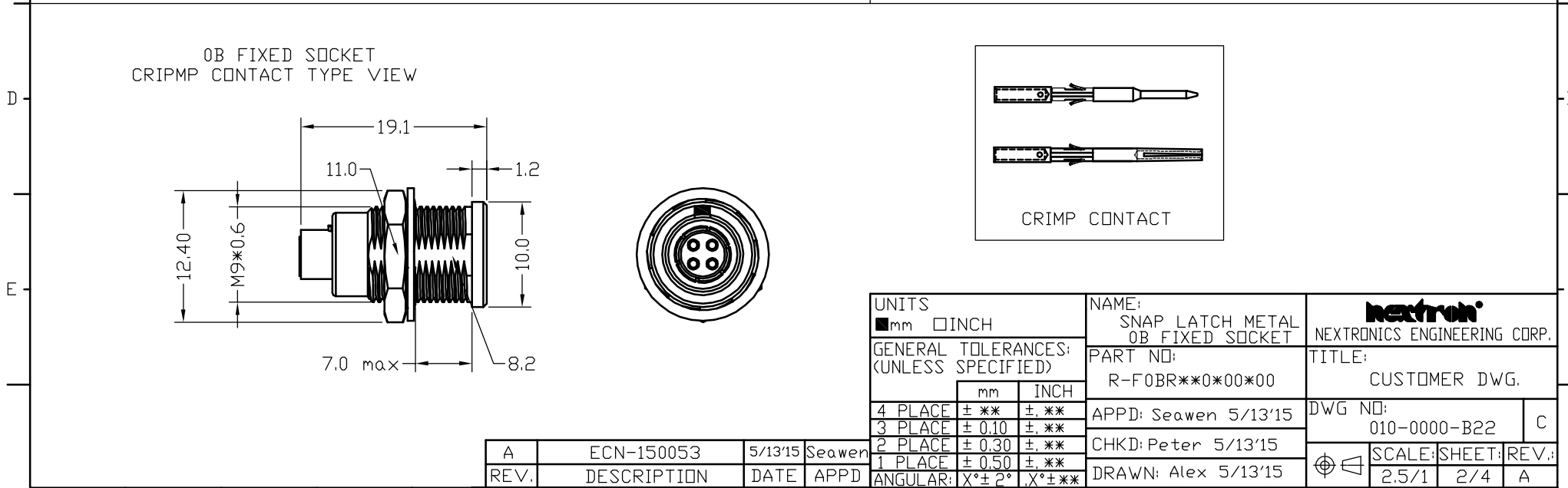
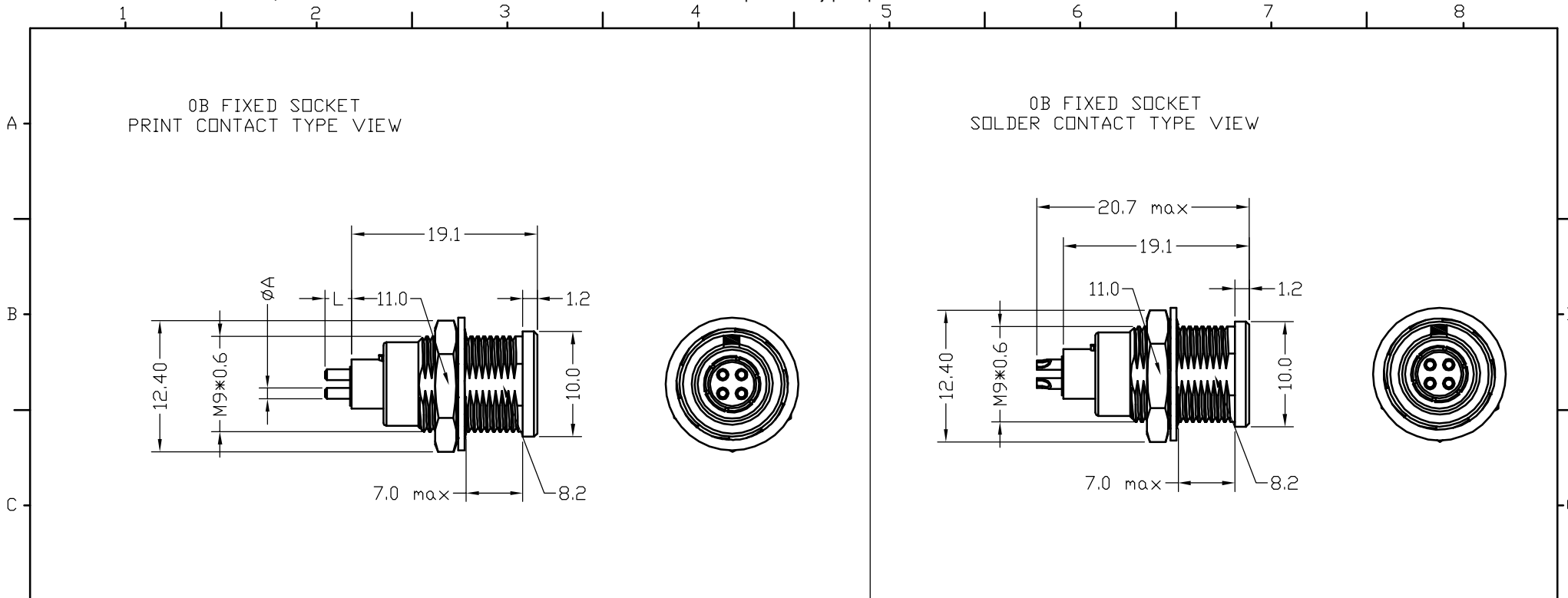

UNITS ■mm □INCH		NAME: SNAP LATCH METAL OB FIXED SOCKET		NEXTRON® NEXTRONICS ENGINEERING CORP.	
GENERAL TOLERANCES: (UNLESS SPECIFIED)		PART NO: R-F0BR**0*00*00		TITLE: CUSTOMER DWG.	
	mm	INCH	APPD: Seawen 5/13'15	DWG NO: 010-0000-B22	C
4 PLACE	± **	± **	CHKD: Peter 5/13'15	SCALE: 2.5/1	SHEET: 2/4
3 PLACE	± 0.10	± **	DRAWN: Alex 5/13'15	REV.: A	
2 PLACE	± 0.30	± **			
1 PLACE	± 0.50	± **			
ANGULAR:	X° ± 2°	X° ± **			

A	ECN-150053	5/13'15	Seawen
REV.	DESCRIPTION	DATE	APPD

KEY ANGLES (RECEPTACLE FRONT VIEW):

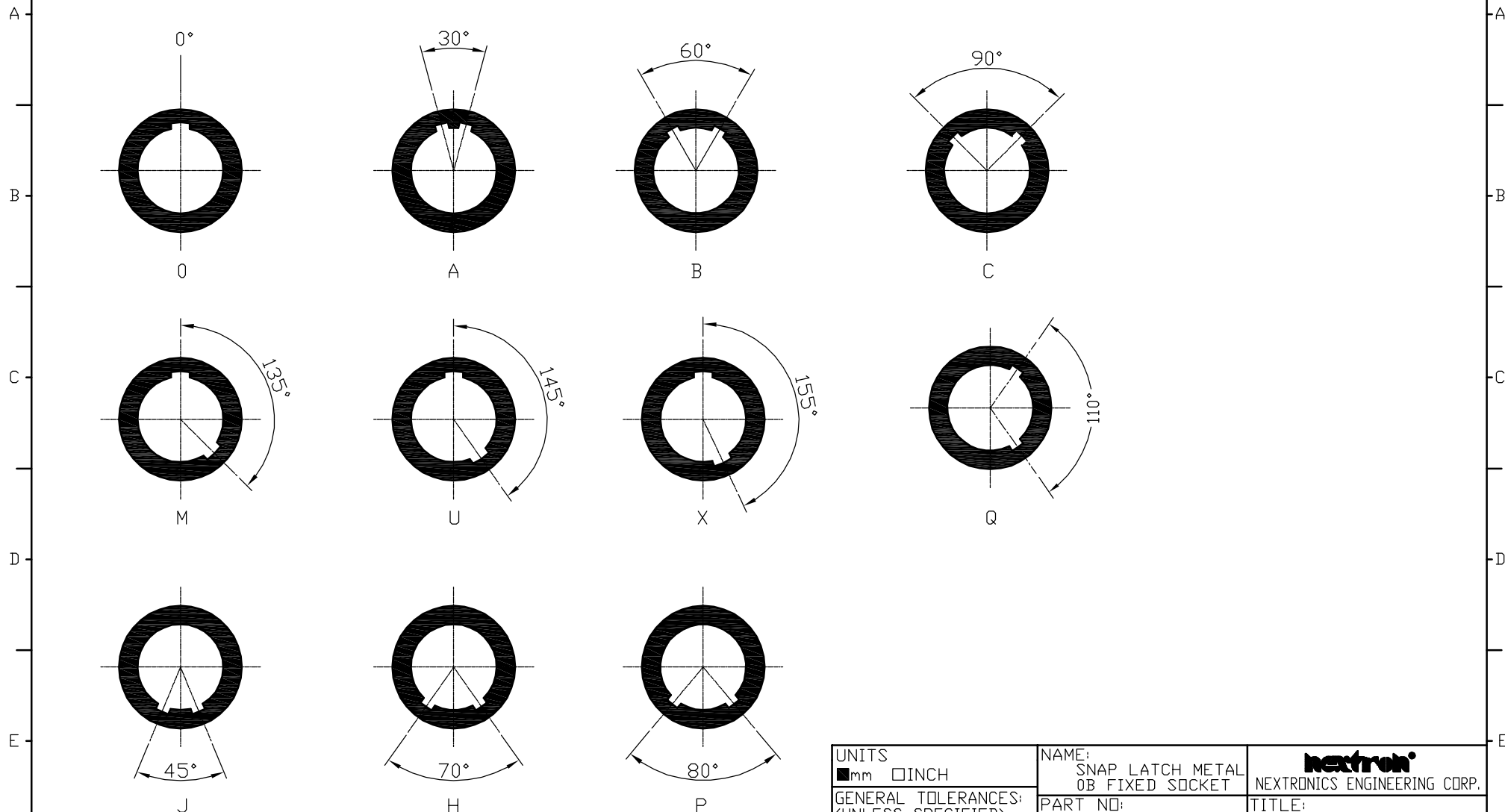

A	ECN-150053	5/13/15	Seawen
REV.	DESCRIPTION	DATE	APPD

UNITS ■mm □INCH	NAME: SNAP LATCH METAL 0B FIXED SOCKET	nextron NEXTRONICS ENGINEERING CORP.	
GENERAL TOLERANCES: (UNLESS SPECIFIED)	PART NO: R-F0BR**0*00*00	TITLE: CUSTOMER DWG.	
	APPD: Seawen 5/13/15	DWG NO: 010-0000-B22	
	CHKD: Peter 5/13/15	C	
	DRAWN: Alex 5/13/15	SCALE: 2.5/1	SHEET: 3/4
ANGULAR: X°±2°		REV.:	A

PCB DRILLING PATTERN

02PIN

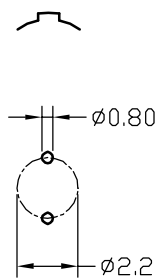

03PIN

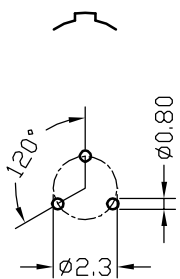

04PIN

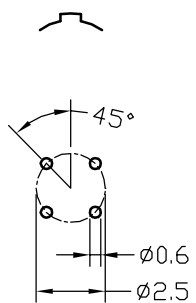

05PIN

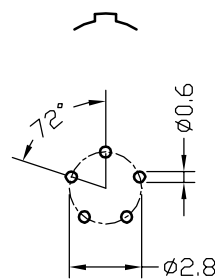

06PIN

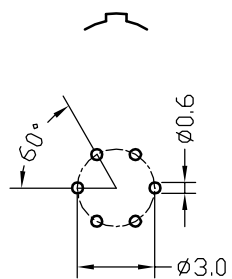

07PIN

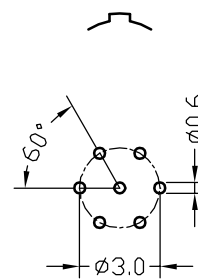

08PIN

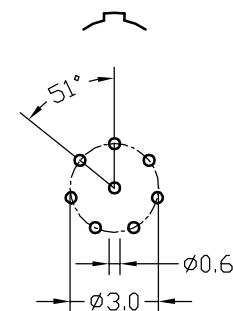

09PIN

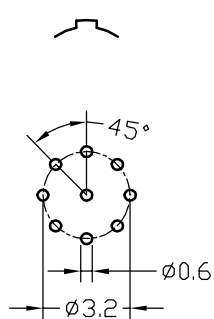

A	ECN-150053	05/13'15	Seawen
REV.	DESCRIPTION	DATE	APPD

UNITS ■mm □INCH		NAME: SNAP LATCH METAL OB FIXED SOCKET		NEXTRON® NEXTRONICS ENGINEERING CORP.	
GENERAL TOLERANCES: (UNLESS SPECIFIED)		PART NO: R-F0BR**0*00*00		TITLE: CUSTOMER DWG.	
	mm	INCH	APPD: Seawen 5/13'15		DWG NO: 010-0000-B22
4 PLACE	± **	± **	CHKD: Peter 5/13'15		C
3 PLACE	± 0.10	± **	DRAWN: Alex 5/13'15		
2 PLACE	± 0.30	± **			
1 PLACE	± 0.50	± **			
ANGULAR:	X° ± 2°	X° ± **			
				SCALE: 2.5/1	SHEET: 4/4
				REV.: A	