

NOTE:

- 1. MATERIAL AND FINISH
 - 1.1. SHELL ASSEMBLY: COPPER ALLOY, OUTER SHELL AND COLLET NUT Cr PLATING, OTHER METALLIC COMPONENTS Ni PLATING
 - 1.2. INSULATOR: PEEK
 - 1.3. CONTACT: COPPER ALLOY, GOLD PLATING
- 2. RoHS COMPLIANCE
- 3. CRIMP CONTACT DETAILS SHOWN IN VIEW 1
- 4. PART NO.

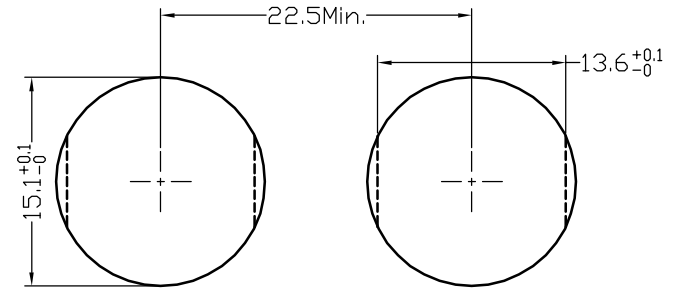

PANEL CUT-OUT

R - F 2 B R * * 0 * 0 0 * 0 0

| |
|------------------|
| CONTACT POS. |
| 02-32=2pin-32pin |

| |
|----------------|
| SHELL MATERIAL |
| 0=Brass |

| CODE | KEY ANGLES |
|------|------------|
| 0 | 0 |
| A | 30° |
| B | 60° |
| " | " |

| No. OF CONTACTS | ØA | L |
|-----------------------|-----|-----|
| 02,03,04,05,06,07, | 0.7 | 3.0 |
| 08,10,12,14,16,18,19, | 0.7 | 3.0 |
| 26,32, | 0.5 | 3.0 |

| CODE | CONTACT TYPE |
|------|-----------------------|
| 2 | Male Solder Contact |
| 4 | Female Solder Contact |
| C | Crimp Male Contact |
| M | Crimp Female Contact |
| 1 | Male Print Contact |
| 3 | Female Print Contact |

| | | | | | |
|---|---------|--|----------------------|------------------------------|-------------------------|
| UNITS <input checked="" type="checkbox"/> mm <input type="checkbox"/> INCH | | NAME: SNAP LATCH METAL 2B FIXED SOCKET | | NEXTRONICS ENGINEERING CORP. | |
| GENERAL TOLERANCES: (UNLESS SPECIFIED) | | PART NO: R-F2BR**0*00*00 | | TITLE: CUSTOMER DWG. | |
| | mm | INCH | APPD: Seawen 3/24'15 | | DWG NO: 010-0000-B30 |
| 4 PLACE | ± ** | ± ** | CHKD: Peter 3/24'15 | | C |
| 3 PLACE | ± 0.10 | ± ** | DRAWN: Alex 3/24'15 | | SCALE: SHEET: REV.: |
| 2 PLACE | ± 0.30 | ± ** | | | 2.5/1 1/7 A |
| 1 PLACE | ± 0.50 | ± ** | | | |
| ANGULAR: | X° ± 2° | X° ± ** | | | |

| REV. | DESCRIPTION | DATE | APPD |
|------|-------------|---------|--------|
| A | ECN-150022 | 3/24'15 | Seawen |

2B FIXED SOCKET SOLDER CONTACT TYPE VIEW

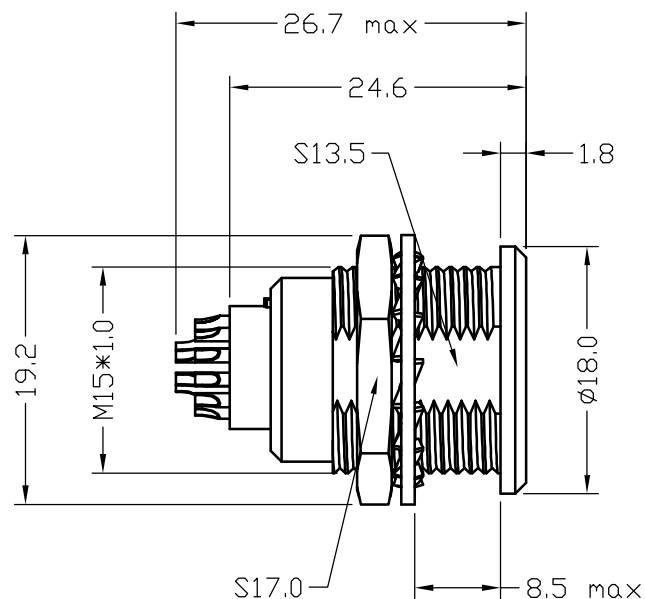

| | | | | | |
|---|---------|--|----------------------|------------------------------|-------------------------|
| UNITS ■mm □INCH | | NAME: SNAP LATCH METAL 2B FIXED SOCKET | | NEXTRONICS ENGINEERING CORP. | |
| GENERAL TOLERANCES: (UNLESS SPECIFIED) | | PART NO: R-F2BR**0*00*00 | | TITLE: CUSTOMER DWG. | |
| | mm | INCH | APPD: Seawen 3/24'15 | | DWG NO: 010-0000-B30 |
| 4 PLACE | ± ** | ± ** | CHKD: Peter 3/24'15 | | C |
| 3 PLACE | ± 0.10 | ± ** | DRAWN: Alex 3/24'15 | | |
| 2 PLACE | ± 0.30 | ± ** | | | |
| 1 PLACE | ± 0.50 | ± ** | | | |
| ANGULAR: | X° ± 2° | X° ± ** | | | |

| | | | |
|------|-------------|---------|--------|
| A | ECN-150022 | 3/24'15 | Seawen |
| REV. | DESCRIPTION | DATE | APPD |

2B FIXED SOCKET PRINT CONTACT TYPE VIEW

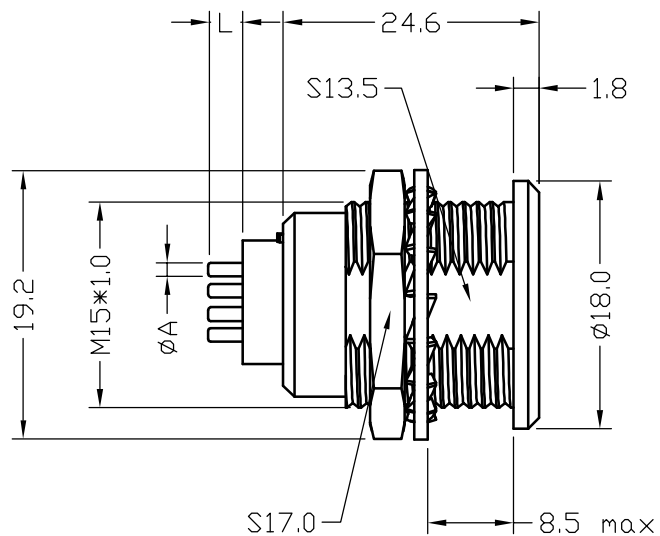

| | | | | | |
|---|---------|--|----------------------|------------------------------|-------------------------|
| UNITS <input checked="" type="checkbox"/> mm <input type="checkbox"/> INCH | | NAME: SNAP LATCH METAL 2B FIXED SOCKET | | NEXTRONICS ENGINEERING CORP. | |
| GENERAL TOLERANCES: (UNLESS SPECIFIED) | | PART NO: R-F2BR**0*00*00 | | TITLE: CUSTOMER DWG. | |
| | mm | INCH | APPD: Seawen 3/24'15 | | DWG NO: 010-0000-B30 |
| 4 PLACE | ± **.05 | ± **.002 | CHKD: Peter 3/24'15 | | C |
| 3 PLACE | ± 0.10 | ± **.004 | DRAWN: Alex 3/24'15 | | |
| 2 PLACE | ± 0.30 | ± **.012 | | | |
| 1 PLACE | ± 0.50 | ± **.020 | | | |
| ANGULAR: | X° ± 2° | X° ± **.075 | | | |

| | | | |
|------|-------------|---------|--------|
| A | ECN-150022 | 3/24'15 | Seawen |
| REV. | DESCRIPTION | DATE | APPD |

2B FIXED SOCKET CRIMP CONTACT TYPE VIEW

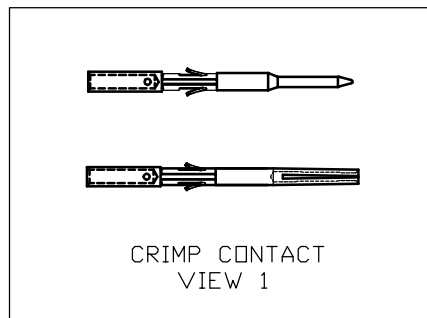
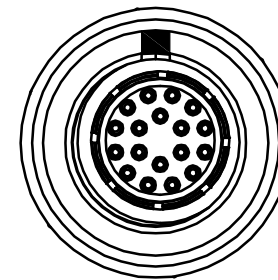
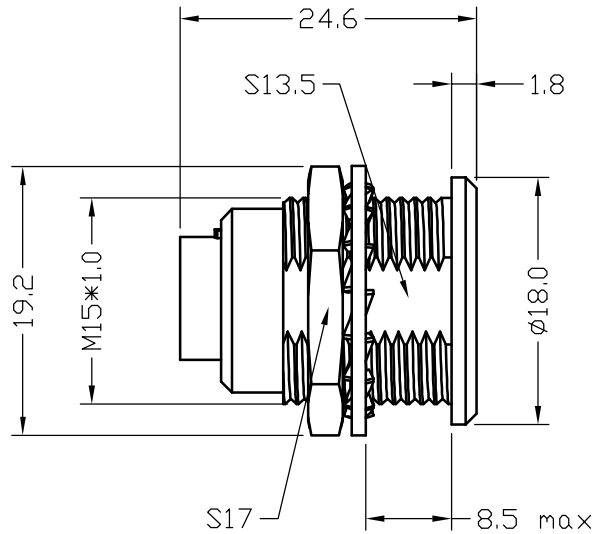

| | | | | | |
|---|---------|--|----------------------|------------------------------|-----|
| UNITS ■mm □INCH | | NAME: SNAP LATCH METAL 2B FIXED SOCKET | | NEXTRONICS ENGINEERING CORP. | |
| GENERAL TOLERANCES: (UNLESS SPECIFIED) | | PART NO: R-F2BR**0*00*00 | | TITLE: CUSTOMER DWG. | |
| | mm | INCH | APPD: Seawen 3/24'15 | DWG NO: 010-0000-B30 | |
| 4 PLACE | ± ** | ± ** | CHKD: Peter 3/24'15 | C | |
| 3 PLACE | ± 0.10 | ± ** | DRAWN: Alex 3/24'15 | SCALE: SHEET: REV.: | |
| 2 PLACE | ± 0.30 | ± ** | | 2.5/1 | 4/7 |
| 1 PLACE | ± 0.50 | ± ** | | | A |
| ANGULAR: | X° ± 2° | X° ± ** | | | |

| | | | |
|------|-------------|---------|--------|
| A | ECN-150022 | 3/24'15 | Seawen |
| REV. | DESCRIPTION | DATE | APPD |

view from termination side pin part

2 POS.

3 POS.

4 POS.

5 POS.

6 POS.

7 POS.

8 POS.

10 POS.

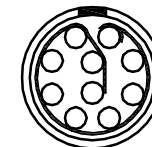
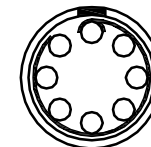
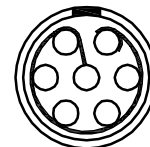
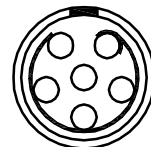
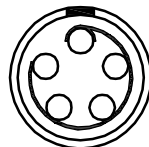
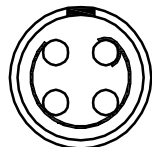
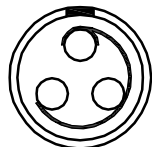
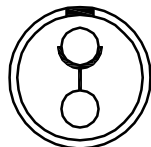

12 POS.

14 POS.

16 POS.

18 POS.

19 POS.

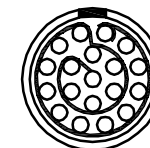
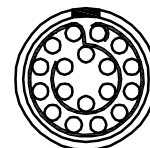
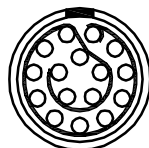

26 POS.

32 POS.

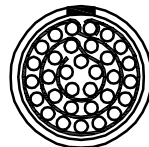
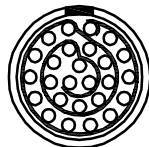

| | | | | | |
|---|---------|--|----------------------|------------------------------|------------------------------------|
| UNITS <input checked="" type="checkbox"/> mm <input type="checkbox"/> INCH | | NAME: SNAP LATCH METAL 2B FIXED SOCKET | | NEXTRONICS ENGINEERING CORP. | |
| GENERAL TOLERANCES: (UNLESS SPECIFIED) | | PART NO: R-F2BR**0*00*00 | | TITLE: CUSTOMER DWG. | |
| | mm | INCH | APPD: Seawen 3/24'15 | | DWG NO: 010-0000-B30 |
| 4 PLACE | ± ** | ± ** | CHKD: Peter 3/24'15 | | C |
| 3 PLACE | ± 0.10 | ± ** | DRAWN: Alex 3/24'15 | | |
| 2 PLACE | ± 0.30 | ± ** | | | |
| 1 PLACE | ± 0.50 | ± ** | | | |
| ANGULAR: | X° ± 2° | X° ± ** | | | SCALE: SHEET: REV.: 2.5/1 5/7 A |

| | | | |
|------|-------------|---------|--------|
| A | ECN-150022 | 3/24'15 | Seawen |
| REV. | DESCRIPTION | DATE | APPD |

KEY ANGLES (RECEPTACLE FRONT VIEW):

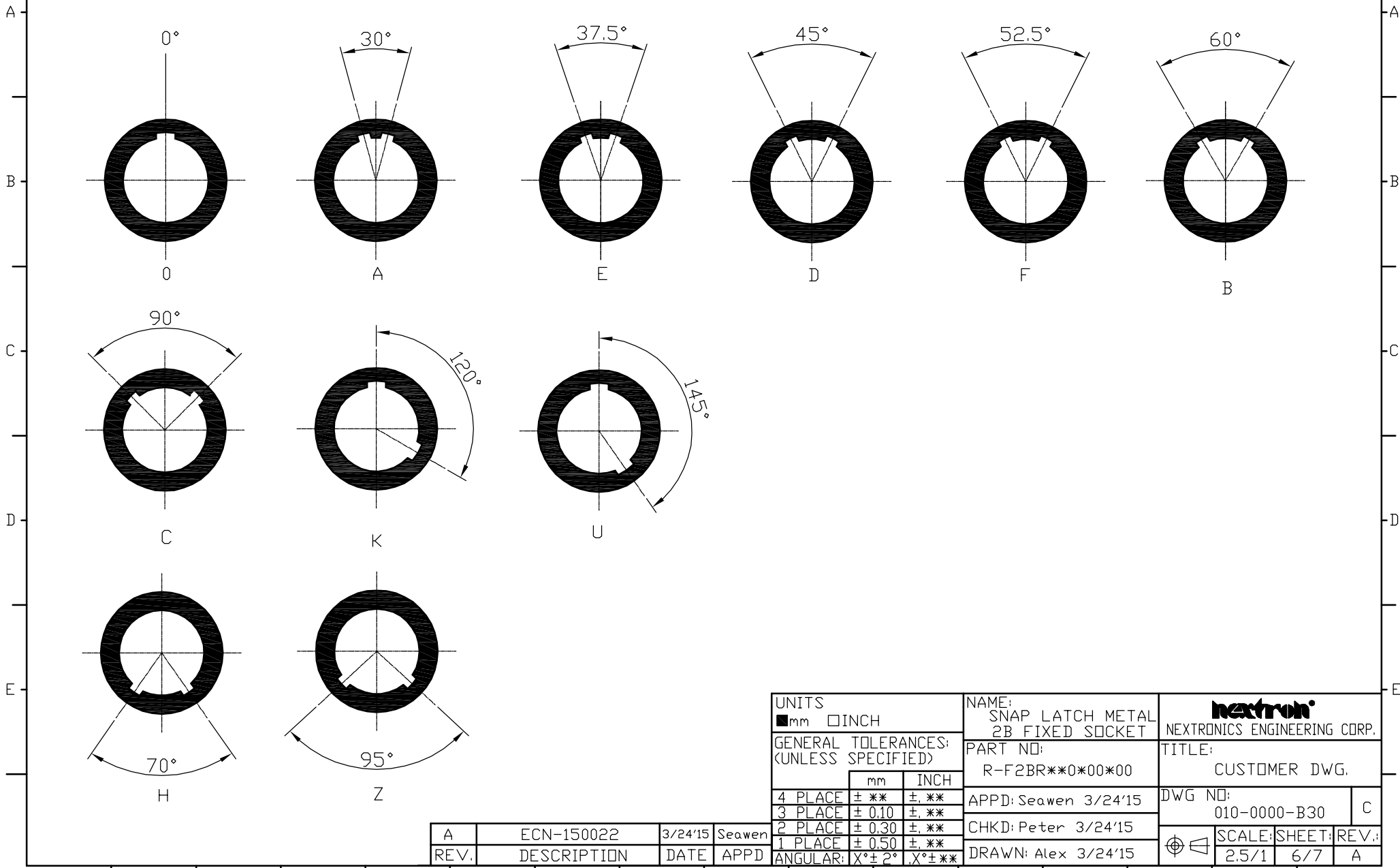

| | | | | | |
|---|---------|--|----------------------|--|-------------------------|
| UNITS ■mm □INCH | | NAME: SNAP LATCH METAL 2B FIXED SOCKET | | NEXTRON [®] NEXTRONICS ENGINEERING CORP. | |
| GENERAL TOLERANCES: (UNLESS SPECIFIED) | | PART NO: R-F2BR**0*00*00 | | TITLE: CUSTOMER DWG. | |
| | mm | INCH | APPD: Seawen 3/24'15 | | DWG NO: 010-0000-B30 |
| 4 PLACE | ± ** | ± ** | CHKD: Peter 3/24'15 | | C |
| 3 PLACE | ± 0.10 | ± ** | DRAWN: Alex 3/24'15 | | |
| 2 PLACE | ± 0.30 | ± ** | | | |
| 1 PLACE | ± 0.50 | ± ** | | | |
| ANGULAR: | X° ± 2° | X° ± ** | | | |

| | | | |
|------|-------------|---------|--------|
| A | ECN-150022 | 3/24'15 | Seawen |
| REV. | DESCRIPTION | DATE | APPD |

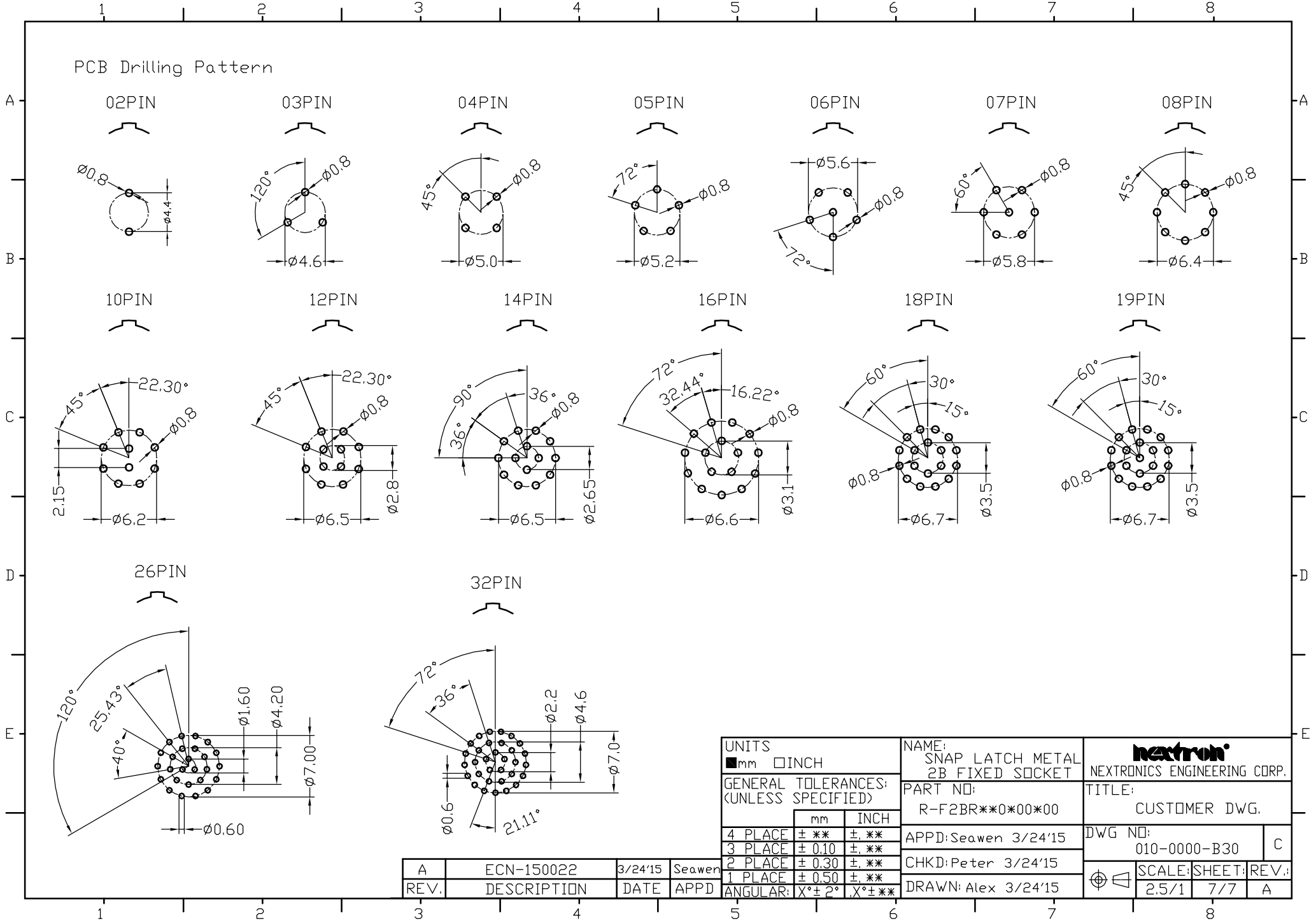

| | | | |
|------|-------------|---------|--------|
| A | ECN-150022 | 3/24'15 | Seawen |
| REV. | DESCRIPTION | DATE | APPD |

| | | | | | |
|---|---------|--|----------------------|--|--|
| UNITS ■mm □INCH | | NAME: SNAP LATCH METAL 2B FIXED SOCKET | | NEXTRON [®] NEXTRONICS ENGINEERING CORP. | |
| GENERAL TOLERANCES: (UNLESS SPECIFIED) | | PART NO: R-F2BR**0*00*00 | | TITLE: CUSTOMER DWG. | |
| | mm | INCH | APPD: Seawen 3/24'15 | DWG NO: 010-0000-B30 | |
| 4 PLACE | ± ** | ± ** | CHKD: Peter 3/24'15 | C | |
| 3 PLACE | ± 0.10 | ± ** | DRAWN: Alex 3/24'15 | SCALE: SHEET: REV.: 2.5/1 7/7 A | |
| 2 PLACE | ± 0.30 | ± ** | | | |
| 1 PLACE | ± 0.50 | ± ** | | | |
| ANGULAR: | X° ± 2° | X° ± ** | | | |

A1

D-PRD-034