

NEXTRON PART NUMBER DESCRIPTION

Z-8242110000X3X

LIGHT PIPE OPTION

- 0=WITHOUT LIGHT PIPE
- 1=WITH INNER & OUTER LIGHT PIPE
- 2=WITH INNER LIGHT PIPE
- 3=WITH OUTER LIGHT PIPE

LOGO OPTION

- 0=WITH NEXTRON LOGO
- 1=WITHOUT LOGO

NOTE:

1. MATERIAL:
 - CAGE ASSEMBLY: COPPER ALLOY, 0.25mm THICKNESS.
 - HOUSING: HIGH TEMPERATURE THERMOPLASTIC, UL94V-0, COLOR: BLACK.
 - INSERTMOLD: HIGH TEMPERATURE THERMOPLASTIC, UL94V-0, COLOR: BLACK.
 - LIGHT PIPE: POLYCARBONATE, CLEAR.
 - CONTACT: COPPER ALLOY, 0.20mm THICKNESS.
2. FINISH:
 - CONTACT: GOLD PLATED ON CONTACT AREA; MATTE TIN PLATED ON TAIL AREA.
 - CAGE: NICKEL PLATED.
3. PC BOARD THICKNESS: 1.5mm MIN.
4. THIS PART MEETS THE RESTRICTION OF HAZARDOUS SUBSTANCES IN ELECTRICAL AND ELECTRONIC EQUIPMENT (ROHS) DIRECTIVE (2011/65/EU).

UNITS ■mm □INCH		NAME: SFP 2X1 CAGE AND CONNECTOR ASSEMBLY, PRESS FIT		nexttron® NEXTRONICS ENGINEERING CORP.	
GENERAL TOLERANCES: (UNLESS SPECIFIED)		PART NO: Z-8242110000X3X		TITLE: CUSTOMER DWG.	
	mm	INCH	APPD: 楊海文 07/01'14	DWG NO: 010-0000-A18	
4 PLACE	± **	±. **	CHKD: 楊海文 07/01'14	C	
3 PLACE	± 0.10	±. **	DRAWN: 廖小瓊 07/01'14	SCALE: SHEET: REV.: 3/2 1/4 B	
2 PLACE	± 0.20	±. **			
1 PLACE	± 0.25	±. **			
ANGULAR:	X° ± 1°	X° ± **			

B	ECN-130255	07/01'14	楊海文
REV.	DESCRIPTION	DATE	APPD

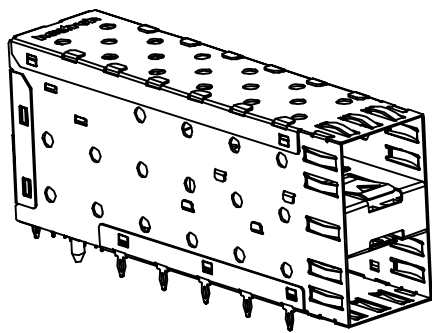

Z-824211000003X AS SHOWN
WITHOUT LIGHT PIPE

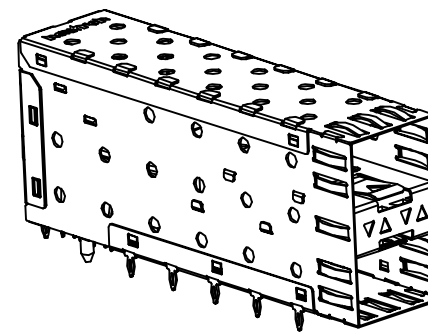

Z-824211000013X AS SHOWN
WITH INNER & OUTER LIGHT PIPES

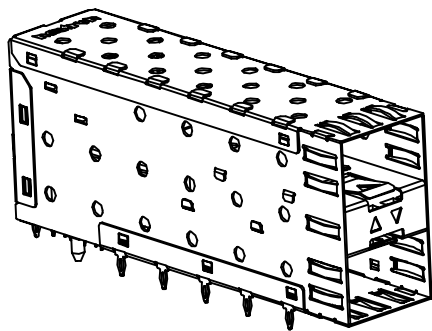

Z-824211000023X AS SHOWN
WITH INNER LIGHT PIPES

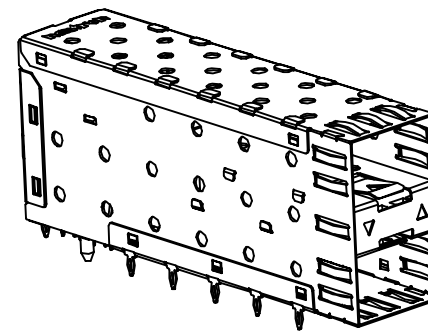

Z-824211000033X AS SHOWN
WITH OUTER LIGHT PIPES

UNITS ■ mm □ INCH		NAME: SFP 2X1 CAGE AND CONNECTOR ASSEMBLY, PRESS FIT		NEXTRONICS ENGINEERING CORP. TITLE: CUSTOMER DWG.	
GENERAL TOLERANCES: (UNLESS SPECIFIED)		PART NO: Z-8242110000X3X			
	mm	INCH	APPD: 楊海文 07/01'14	C	
4 PLACE	± **	±. **	CHKD: 楊海文 07/01'14	SCALE: SHEET: REV.:	
3 PLACE	± 0.10	±. **	DRAWN: 廖小瓊 07/01'14	3/2	2/4
2 PLACE	± 0.20	±. **			B
1 PLACE	± 0.25	±. **			
ANGULAR:	X° ± 1°	X° ± **			

B	ECN-130255	07/01'14	楊海文
REV.	DESCRIPTION	DATE	APPD

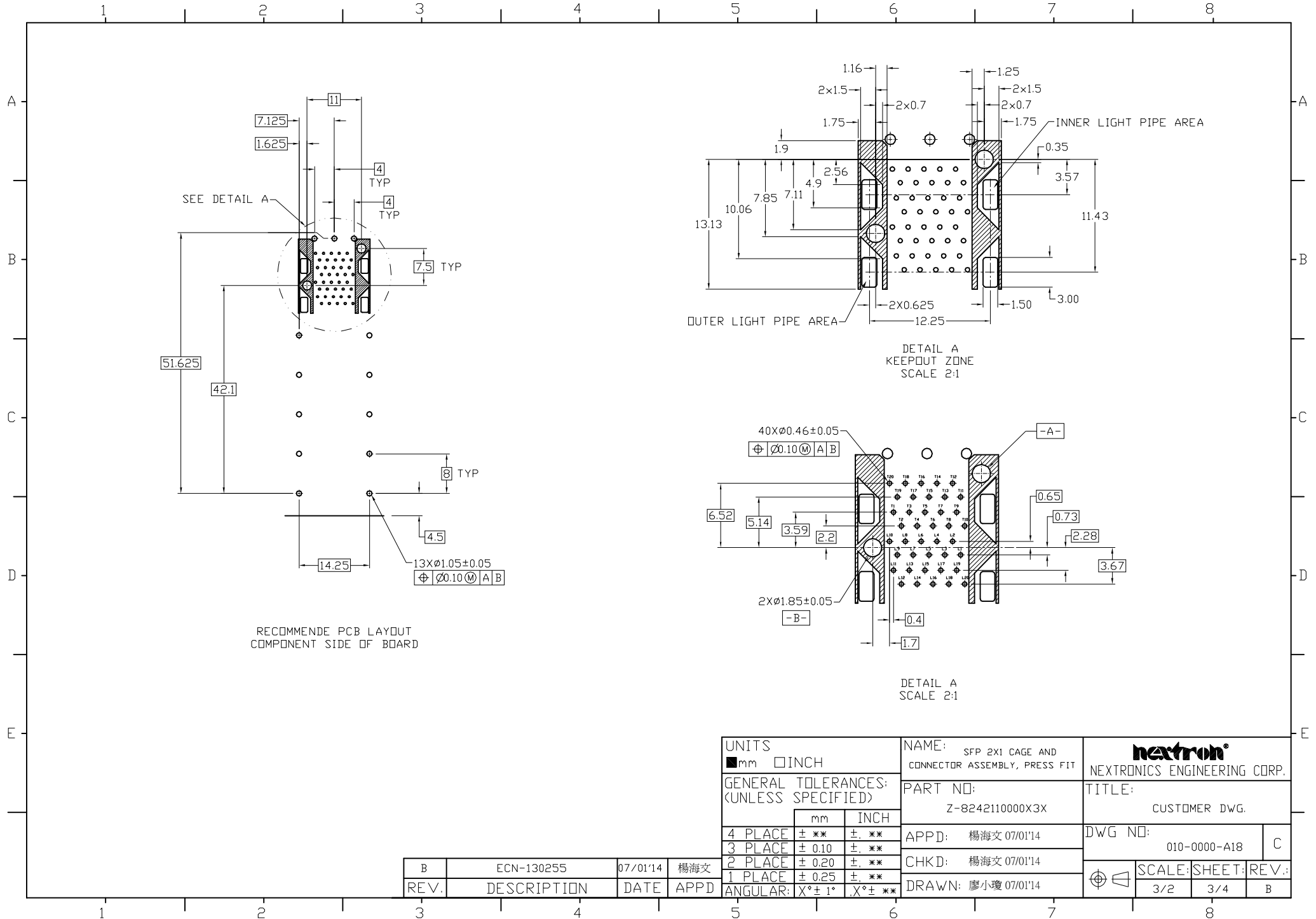

RECOMMENDE PCB LAYOUT
COMPONENT SIDE OF BOARD

UNITS ■ mm □ INCH		NAME: SFP 2X1 CAGE AND CONNECTOR ASSEMBLY, PRESS FIT		NEXTRONICS ENGINEERING CORP. TITLE: CUSTOMER DWG.	
GENERAL TOLERANCES: (UNLESS SPECIFIED)		PART NO: Z-8242110000X3X			
		mm	INCH	APPD: 楊海文 07/01'14	C
4 PLACE	± **	± **. **		CHKD: 楊海文 07/01'14	
3 PLACE	± 0.10	± **. **		DRAWN: 廖小瓊 07/01'14	
2 PLACE	± 0.20	± **. **		SCALE: SHEET: REV.:	
1 PLACE	± 0.25	± **. **		3/2 3/4 B	
ANGULAR:	X° ± 1°	X° ± **. **			

B	ECN-130255	07/01'14	楊海文
REV.	DESCRIPTION	DATE	APPD

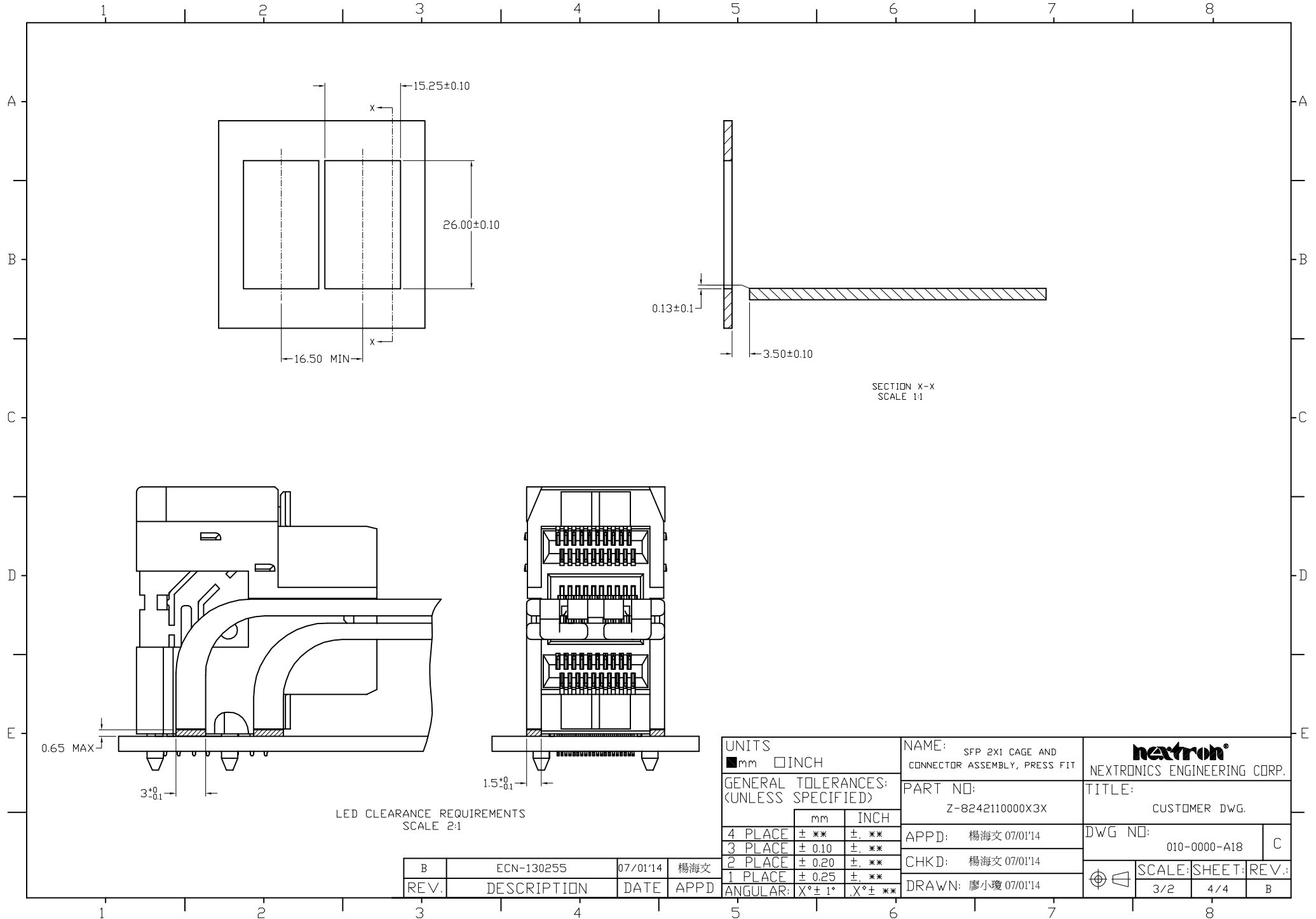

SECTION X-X
SCALE 1:1

LED CLEARANCE REQUIREMENTS
SCALE 2:1

UNITS ■ mm □ INCH		NAME: SFP 2X1 CAGE AND CONNECTOR ASSEMBLY, PRESS FIT		NEXTRONICS ENGINEERING CORP.	
GENERAL TOLERANCES: (UNLESS SPECIFIED)		PART NO: Z-8242110000X3X		TITLE: CUSTOMER DWG.	
	mm	INCH	APPD: 楊海文 07/01'14	DWG NO: 010-0000-A18	
4 PLACE	± **	±. **	CHKD: 楊海文 07/01'14	C	
3 PLACE	± 0.10	±. **	DRAWN: 廖小瓊 07/01'14	SCALE: SHEET: REV.:	
2 PLACE	± 0.20	±. **		3/2	4/4
1 PLACE	± 0.25	±. **			B
ANGULAR:	X° ± 1°	X° ± **			

B	ECN-130255	07/01'14	楊海文
REV.	DESCRIPTION	DATE	APPD